

STANDARD HOLE PROCESSING EXAMPLES ②

Unless indicated otherwise, the end face of the hole plates is C0.5. The applications illustrated here are just processing examples. In actual application, it is necessary to consider a wide array of conditions and requirements, including pitch between holes, perpendicularity of the holes, surface roughness, roundness, plate material, parallelism, whether or not quenching is required, molding machine precision, product production volume, and tool wear. For this reason, please understand that MISUMI cannot accept any responsibility for problems that may arise from use of these examples.

Locking Block with Angular Hole Process

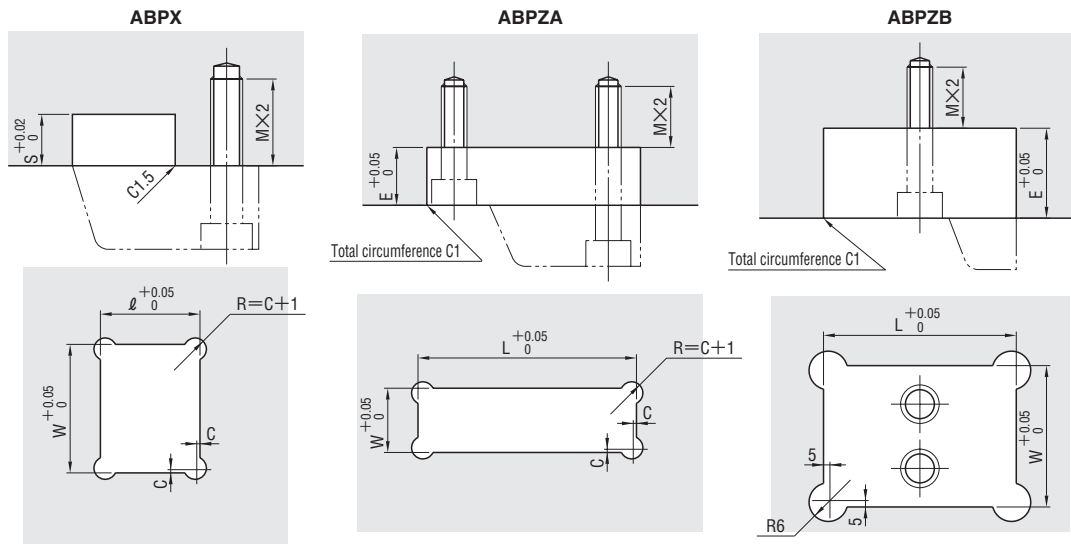

Guide Rail

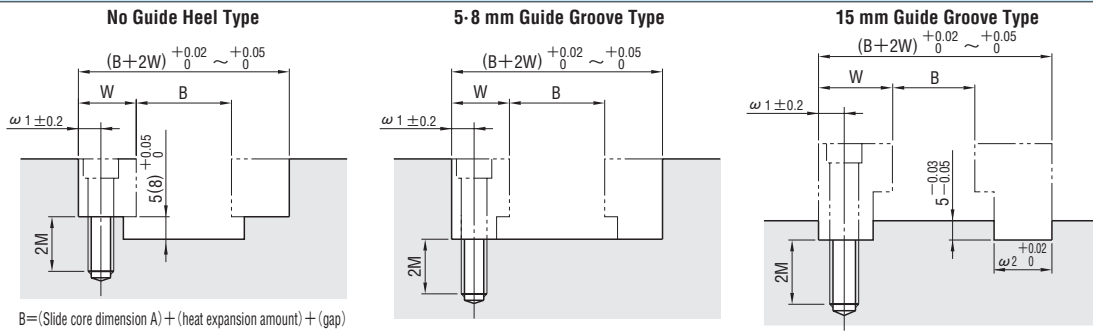

Center Rail

• Slide core for center rail

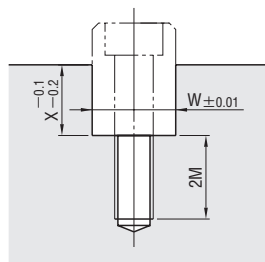
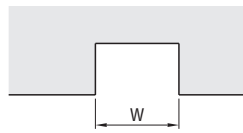

X is an elective dimension

Center Type Guide Rail

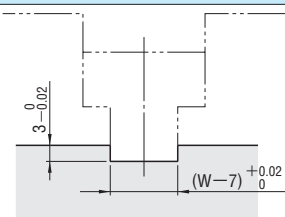

Ball Plunger and Ball Button

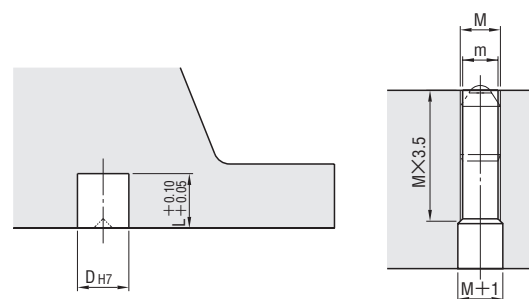

Locating Ring

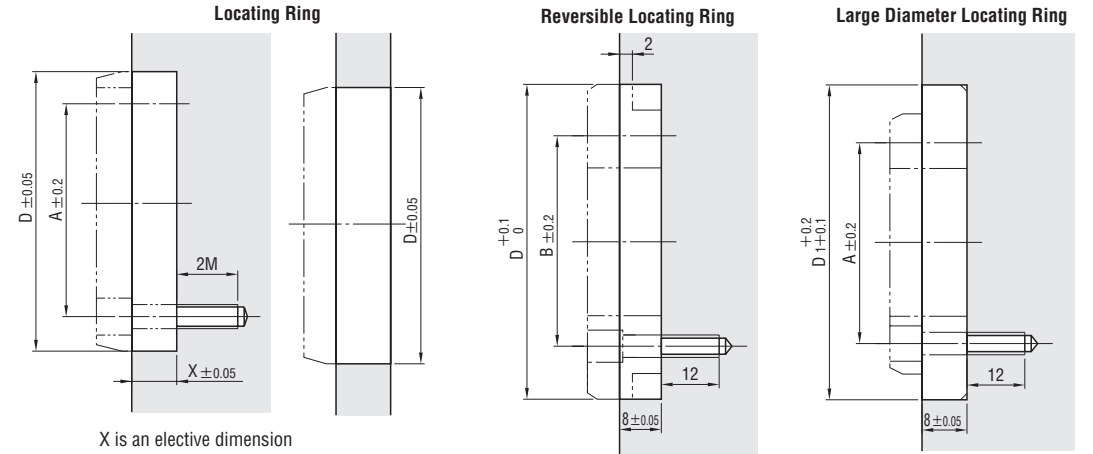

Sprue Bushing

