

[Technical Data] Selection of Single Axis Actuators 1

Selection is easy with Single Actuator calculation tool available at: http://fawos.misumi.jp/FA_WEB/unit/web/misumi_LX_en.html

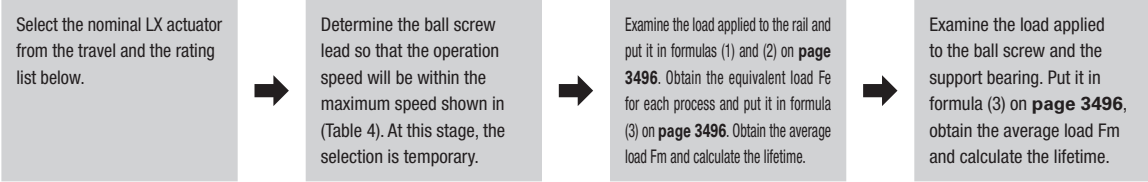

Rated load (Table 1)

Item	LX2001	LX2005	LX2602	LX2605	LX3005	LX3010	LX4510	LX4520	
Rail	Dynamic load rating Ca (N)	3277	6522	9732	6305	18450	11826		
	Static load rating Coa (N)	6199	11871	17218	9271	32441	17175		
Radial clearances		-3~0	-4~0	-4~0	-6~0				
Ball screw	Dynamic load rating Ca (N) Advanced	482	822	1712	1600	1831	1129	4167	2499
	Static load rating Coa (N) Advanced	642	1026	2251	2097	2389	1386	5945	3381
	Thread shaft diameter (mm)	6	6	8	8	10	10	15	15
	Lead (mm)	1	5	2	5	5	10	10	20
	Core diameter	5.3	4.918	6.4	6.46	8.2		11.7	
Ball center diameter		6.15	6.3	8.3	8.3	10.3	10.3	15.5	15.75
Bearing (fixed side)	Axial load	Dynamic load rating Ca (N)	730	1637	2702	4335			
		Static load rating Coa (N)	461	1205	2197	4106			

Moment equivalent coefficient at rail (Table 2)

Type	Block	Kp	Ky	Kr
LX20_ _	1 piece	0.228	0.228	0.0667
	Close contact between 2 pcs.	0.144	0.144	0.0667
LX26_ _	1 piece	0.17	0.17	0.0527
	Close contact between 2 pcs.	0.114	0.114	0.0527
LX30_ _	1 piece	0.137	0.137	0.0445
	Close contact between 2 pcs.	0.0917	0.0917	0.0445
LX45_ _	1 piece	0.1115	0.1115	0.0334
	Close contact between 2 pcs.	0.0840	0.0840	0.0334

Rail geometrical moment of inertia (Table 3)

Type	Lx (mm ⁴)	Ly (mm ⁴)	Mass (kg/100mm)	Center of Gravity h (mm)
LX2001	3.2×10 ³	5.2×10 ⁴	0.22	4.4
LX2606	1.0×10 ⁴	1.4×10 ⁵	0.37	6.1
LX30_ _	2.5×10 ⁴	3.1×10 ⁵	0.6	7.8
LX45_ _	8.8×10 ⁴	10.4×10 ⁵	1.10	11.0

Allowable Static Load / Allowable Static Moment (Table 4)

Type	No. of blocks	Allowable Static Load (kg)	Allowable Static Moment (N-m)		
			Horizontal	Ma	Mb
LX20_ _	B1	6199	27	27	93
	B2	12398	353	353	186
LX20_ _C	B1	6199	27	27	93
	B2	12398	353	353	186
LX26_ _	B1	11871	70	70	225
	B2	23742	902	902	450
LX26_ _C	B1	11871	70	70	225
	B2	23742	902	902	450
LX3005	B1	17218	126	126	387
	B2	34436	1515	1515	774
LX3005C	B1	17218	126	126	387
	B2	34436	1515	1515	774
LX3010	B1	17218	126	126	387
	B2	34436	1515	1515	774
LX3010C	B1	17218	126	126	387
	B2	34436	1515	1515	774
LX4510	B1	32441	291	291	972
	B2	64882	3945	3945	1944
LX4520	B1	32441	291	291	972
	B2	64882	3945	3945	1944

Maximum travel speed (Table 6)

Type	Lead	L (mm)	Maximum travel speed (mm/s)	
			Standard	Advanced
LX20_ _	01	-	190	
	05	-	690	
LX26_ _	02	-	290	
	05	-	520	
LX30_ _	06	150	410	
		200	410	
		300	410	
		400	410	
		500	370	
	10	600	250	
		150	830	
		200	830	
		300	830	
		400	830	
LX45_ _	10	500	740	
		600	500	
		340	550	
		390	550	
		440	550	
	20	490	550	
		540	550	
		590	550	
		340	1110	
		390	1110	
LX4520	440	1110		
	490	1110		
	540	1110		
	590	1110		
	590	1110		

Load coefficient fw (Table 7)

Vibration/impact	Speed	fw
Subtle	Super-low speed V ≤ 0.25m/s	1~1.2
	Small	Low speed 0.25m/s < V ≤ 1m/s
Medium	Medium speed 1m/s < V ≤ 2m/s	1.5~2
	Large	High speed 2m/s < V

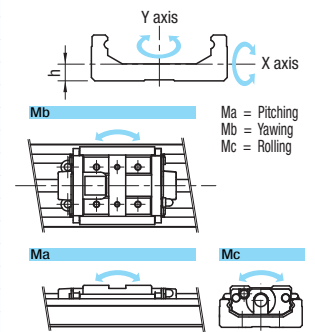

Allowable Static Load / Allowable Static Moment (Short Block) (Table 5)

Type	No. of blocks	Allowable Static Load (kg)	Allowable Static Moment (N-m)		
			Horizontal	Ma	Mb
LX3005	S1	9271	63	63	208
	S2	18542	579	579	417
LX3010	S1	9271	63	63	208
	S2	18542	579	579	417
LX4510	S1	17175	145	145	515
	S2	34350	1444	1444	1029
LX4520	S1	17175	145	145	515
	S2	34350	1444	1444	1029

Life Span

For the LX actuator, calculate the life span of the rail, ball screw and support bearing. The actuator life span is determined to be the smallest value from among these results.

- Load mass : W kg
- Stroke : Ls mm
- Acceleration : a mm/s²
- Maximum speed : v mm/s
- Gravity : g=9.81m/s²
- acceleration : Horizontal
- Speed diagram : (Fig. 1)
- Operating conditions : (Fig. 2)

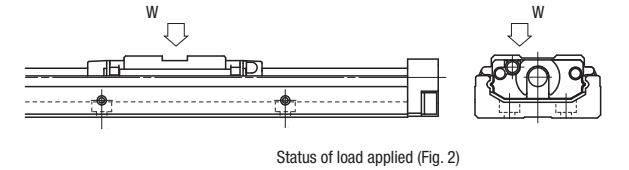
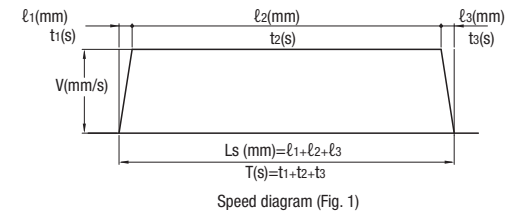

Examination Selection

Select the temporary model number based on the load mass W (kg) and the maximum speed V (mm/s). Then prepare a speed diagram based on the acceleration, maximum speed and travel. The conditions that can develop this speed diagram will serve as the basis for the selection calculation.

Calculation Lifetime Calculation Example

Examine the status of the load applied (Fig. 2) to the rail of the LX actuator. Put each load in the formula below (formula (1) for single nut block specifications and formula (2) for double nut block specifications), and obtain the equivalent load Fe.

Equivalent Load

• In the case of single block

$$Fe = Y_H F_H + Y_V F_V + Y_P K_P M_a + Y_Y K_Y M_b + Y_R K_R M_c \quad (1)$$

• In the case of double block

$$Fe = Y_H F_H / 2 + Y_V F_V / 2 + Y_R K_R M_a + Y_P K_P M_b + Y_Y K_Y M_c \quad (2)$$

- Fe : Equivalent Load
- FH : Horizontal load acting on blocks
- Fv : Vertical load applied to the block
- Ma : Pitching direction moment applied to the block
- Mb : Yawing direction moment applied to the block
- Mc : Rolling direction moment applied to the block
- Kp : Equivalent coefficient for pitching direction moment
- Ky : Equivalent coefficient for yawing direction moment
- Kr : Equivalent coefficient for rolling direction moment
- YH, YV, YP, YR: 1.0 or 0.5

When the actuator is used under moment loads, calculate the load by multiplying the guide moment equivalent coefficient in Table 2. In formulas (1) and (2), in order to obtain the equivalent load Fe, the maximum value among FH, Fv, KpMa, KyMb and KrMc is determined to be 1.0, and the remaining items are set at 0.5.

Average Load

As Ma and Mb for the LX actuator vary with acceleration and deceleration, obtain the average load Fm from formula (3).

$$Fm = \sqrt[3]{\frac{1}{Ls} (Fe_1^3 \cdot L_1 + Fe_2^3 \cdot L_2 + Fe_3^3 \cdot L_3 + Fe_n^3 \cdot L_n)} \quad (3)$$

Fm: Average load for fluctuating loads (N) L: Total travel distance (km)

Rail Life Span

Obtain the rail life span for the LX actuator from formula (4).

$$L = L_a \times \left(\frac{C}{f_w \cdot F_m} \right)^3 \quad (4)$$

L: Rail lifetime (km) La: Travel distance (km) fw: Load coefficient C: Basic dynamic load rating (N)

When the travel length and the number of reciprocal motions per minute are constant, the number of life span hours can be calculated from formula (5).

$$L_h = \frac{L \times 10^6}{2 \cdot \ell_s \cdot n_1 \times 60} \quad (5)$$

Lh: Life span hours (h) ℓs: Travel (mm) n1: Reciprocal motions per minute

Life span of ball screw and support areas

Obtain the average load from the load applied in the axial direction. Calculate life span for both ball screws and bearings from formula (6). Obtain the average load from formula (3).

$$L_r = \left(\frac{C_a}{f_w \cdot F_m} \right)^3 \cdot \ell \times 10^6 \quad (6)$$

Lr: Life span of ball screw (km) ℓ: Ball screw lead (mm) fw: Load coefficient Ca: Basic dynamic load rating of screw and support (N)

[Technical Data] Selection of Single Axis Actuators 2

Selection is easy with Single Actuator calculation tool available at: http://fawos.misumi.jp/FA_WEB/unit/web/misumi_LX_en.html

Rated lifetime calculation example

1 Model number for examination

Operating conditions : LX26
 Rail : C (Basic dynamic load rating)=6522N Co (Basic static load rating)=11871N
 Ball screw : Ca (Basic dynamic load rating)=1712N Coa (Basic static load rating)=2251N
 Support bearings : Ca (Basic dynamic load rating)=1637N Poa (Basic static load rating)=1205N

Load mass : 10kg
 Maximum speed : 250mm/s
 Acceleration : 833mm/s²
 Stroke : 200mm
 Gravity : g=9.81m/s²
 Position : Horizontal
 Speed diagram : (Fig. 1)
 Operating Conditions : (Fig. 2)

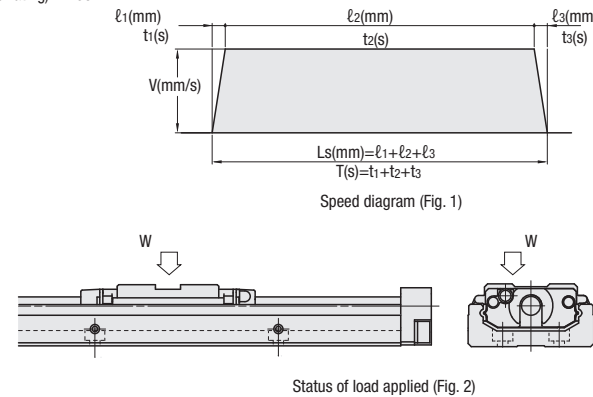

2 Examination

Temporary selection

Use a travel distance of 200 mm with an acceleration of 833 mm/s² and a maximum speed of 250 mm/s. Based on these conditions, assume that the LX26 series is used. (The selection software can be used on the Misumi website after customer registration has been completed.)

3 Calculation

3-1 Examination of rail

Multiply the moment equivalent coefficient in the table with the load according to the condition in which one nut block is used.

Load for nut block

- At constant speed
 $Fe_1 = Y_v F_v - W \cdot g = 1 \cdot 10 \cdot 9.81 = 98.1(N)$
- At acceleration
 $Fe_2 = Y_v F_v + Y_p K_p M a = 0.5 \cdot 98.1 + 1 \cdot 0.17 \cdot 70 \cdot 0 = 60.95(N)$
- At deceleration
 $Fe_3 = Y_v F_v + Y_p K_p M a = 0.5 \cdot 98.1 + 1 \cdot 0.17 \cdot 70 \cdot 0 = 60.95(N)$

Static safety coefficient

$$f_s = \frac{C_o}{F_{max}} = \frac{C_o}{W \cdot g} = \frac{11871}{98.1} = 121.1$$

Rated life span

Axial average load

$$F_m = \sqrt[3]{\frac{1}{L_s} (F_{e1}^3 \cdot L_1 + F_{e2}^3 \cdot L_2 + F_{e3}^3 \cdot L_3 \cdot F_{en}^3 \cdot L_n)} = 87.72(N)$$

Rated life span

$$L = \left(\frac{C}{f_w \cdot F_m} \right)^3 \times 50 = 11.89 \times 10^6$$

fw: Load coefficient 1.2
La: Travel distance

3-2 Examination of ball screw

Obtain the axial loads for the parts and the average load from the speed diagram.

Lifetime of ball screw

Axial load

- At constant speed
 $Fe_1 = \mu \cdot W \cdot g = 0.01 \times 10 \times 9.81 = 0.981(N)$
- At acceleration
 $Fe_2 = Fe_1 + W \cdot a \times 10^{-3} = 0.981 + 10 \cdot 0.833 = 9.311(N)$
- At deceleration
 $Fe_3 = Fe_1 - W \cdot a \times 10^{-3} = 7.352(N)$

Static safety coefficient

$$f_s = \frac{C_{oa}}{F_{max}} = \frac{C_{oa}}{Fe_2} = \frac{2251}{9.311} = 241.76$$

Buckling load

$$P_1 = \frac{n \cdot \pi^2 \cdot E \cdot I}{\ell a^2} \times 0.5 = 5562.02(N)$$

P₁: Buckling load
 ℓa: Distance between mounting points 250(mm)
 E: Young's modulus 2.06×10⁵(N/mm²)
 n: Coefficient according to mounting method
 0.5: Safety factor
 I: Minimum geometrical moment of inertia of screw shaft

$$I = \frac{\pi \cdot d_1^4}{64} = 85.49(mm^4)$$

d₁: Root diameter of screw shaft 6.46(mm)

Allowable tension/compression load

$$P_2 = \frac{\delta \cdot \pi \cdot d_1^2}{4} = 4818.06$$

P₂: Allowable tension/compression load (N)
 δ: Allowable tension/compression stress 147(N/mm²)
 d₁: Root diameter of screw shaft 6.46(mm)

Critical speed

$$N_1 = \frac{60 \cdot \lambda^2}{2\pi \cdot \ell b^2} \cdot \sqrt{\frac{E \times 10^3 \cdot I}{\gamma \cdot A}} \times 0.8 = 12485(min^{-1})$$

N₁: Critical speed
 ℓb: Distance between mounting points
 E: Young's modulus 2.06×10⁵(N/mm²)
 λ: Coefficient according to mounting method (Fixed-Support 3.927)
 γ: Density (7.85×10⁻⁶kg/mm³)
 0.8: Safety factor

DN value

$$DN = 62250(\leq 70000)$$

D: Ball center to center diameter (8.3mm)
 N: Maximum number of operating revolutions (min⁻¹)

LX2602	Rail	Ball screw	Support bearing
Static safety factor	121.1	241.76	129.42
Buckling load (N)	-	5562.02	-
Allowable tension/compression load (N)	-	4818.06	-
Critical speed (min ⁻¹)	-	12485	-
DN value	-	62250	-
Rated lifetime (km)	11.89×10 ⁶	22.31×10 ⁶	19.505×10 ⁶
Maximum axial load (N)	-	9.311	-
Maximum number of operating revolutions	-	7500	-

Rated life span

Axial average load

$$F_m = \sqrt[3]{\frac{1}{L_s} (F_{e1}^3 \cdot L_1 + F_{e2}^3 \cdot L_2 + F_{e3}^3 \cdot L_3 \cdot F_{en}^3 \cdot L_n)} = 6.096(N)$$

Rated life span

$$L = \left(\frac{C_a}{f_w \cdot F_m} \right)^3 \cdot \ell \times 10^6 = 25.64 \times 10^6(km)$$

fw: Load coefficient 1.2
 ℓ: Ball screw lead 2 (mm)

3-3 Examination of support bearing

Axial load

Fe₁=0.981(N)
 Fe₂=9.311(N)
 Fe₃=7.352(N)

Static safety coefficient

$$f_s = \frac{P_{oa}}{F_{max}} = \frac{P_{oa}}{Fe_2} = 129.42$$

Equivalent load

Axial average load

$$F_m = \sqrt[3]{\frac{1}{L_s} (F_{e1}^3 \cdot L_1 + F_{e2}^3 \cdot L_2 + F_{e3}^3 \cdot L_3 \cdot F_{en}^3 \cdot L_n)} = 6.096(N)$$

Rated lifetime

$$L = \left(\frac{C_a}{f_w \cdot F_m} \right)^3 \cdot \ell \times 10^6 = 22.41 \times 10^6(km)$$

fw: Load coefficient 1.2
 ℓ: Ball screw lead 2 (mm)