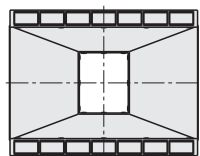
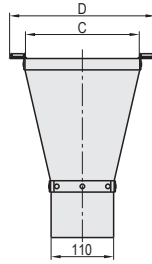
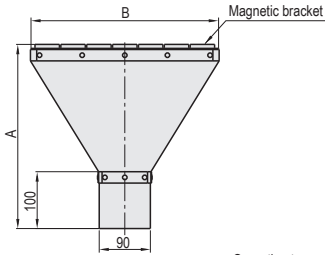

■ Fabric Chute for Engineering Plastics **M-SHT-EPCS**

Operating temperature: 500°C
 Material Metal part: SPHC

■ Features

- A fabric chute made of heat-resistant, cutting-resistant and high-strength special fibers.
- The chute is attached to the mold with a magnet. It operates in conjunction with the opening and closing of the mold, and gently receives the products.
- This product has a wide range of installation options, such as use alone or insertion into a reversal chute to be dropped onto a conveyor.

Part Number		A	B	C	D	Unit Price
Type	No.					1 pc
M-SHT-EPCS	30	350	280	220	280	Quotation
	50		330			
	100	400	420	290	350	



Example

When combined with a reversal chute



Order

Part Number
M-SHT-EPCS-30



Days to Ship

Quotation



Price

Quotation