

COOLING MANIFOLD WITH THERMOMETER / SIMPLE FLOW METER

■ Application Use to distribute / branch out cooling water.



■ Features

- Comes with a thermometer and simple flow meter to check temperature and flow rate simultaneous.
- Hose nipples can be removed.

■ Material: Polyamide/Brass
Manifold: Aluminum alloy

Usable temperature (Oil) (°C)	120 or less
Usable temperature (Water) (°C)	80 or less
Allowable pressure (MPa)	0.98
Max. flow rate (ℓ/min)	10

M-CMF-B-2-2

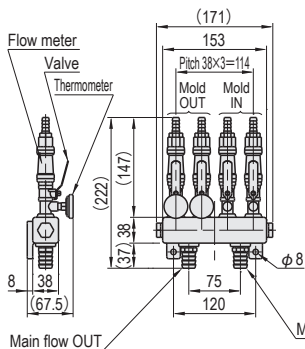

M-CMF-B-3-3

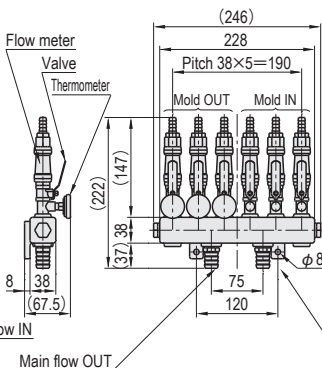

M-CMF-B-4-4

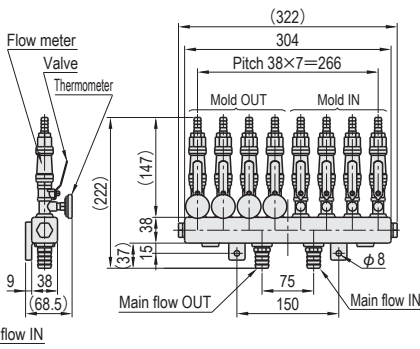

M-CMF-B-6-6

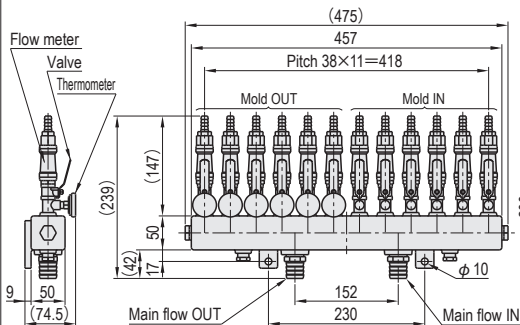

M-CMF-B-10-10

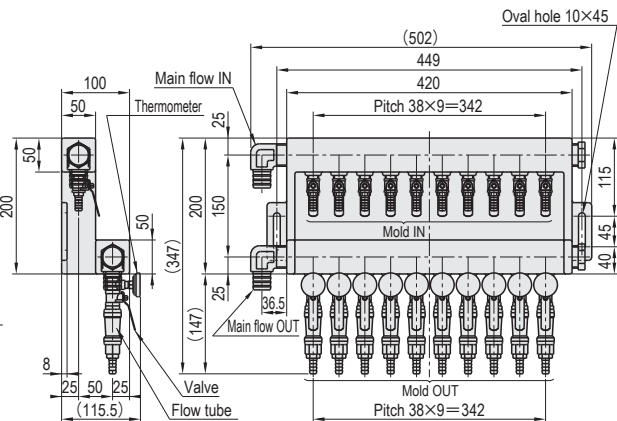

Width	Number of branches IN x OUT	Main flow inner dia.	Main flow compatible hose inner dia.	Mold compatible hose inner dia.	Main flow joint RC(PT)	Mold joint RC(PT)	Part Number		Unit Price
							Type	No.	
171	2x2	16	19	9.5	1/2	3/8	M-CMF-B	2-2	Quotation
246	3x3							3-3	
322	4x4	4-4							
475	6x6	6-6							
502	10x10	20	25		1		10-10		



Order

Part Number
M-CMF-B-4-4



Days to Ship

Quotation



Price

Quotation

COMPONENTS FOR MOLD COOLING AND TEMPERATURE CONTROLLING SYSTEMS