

Dies Steel
SKD61 equivalent
+
Nitriding

PINS FOR EJECTOR BLOCK

Ⓜ Non JIS material definition is listed on P.1351 - 1352

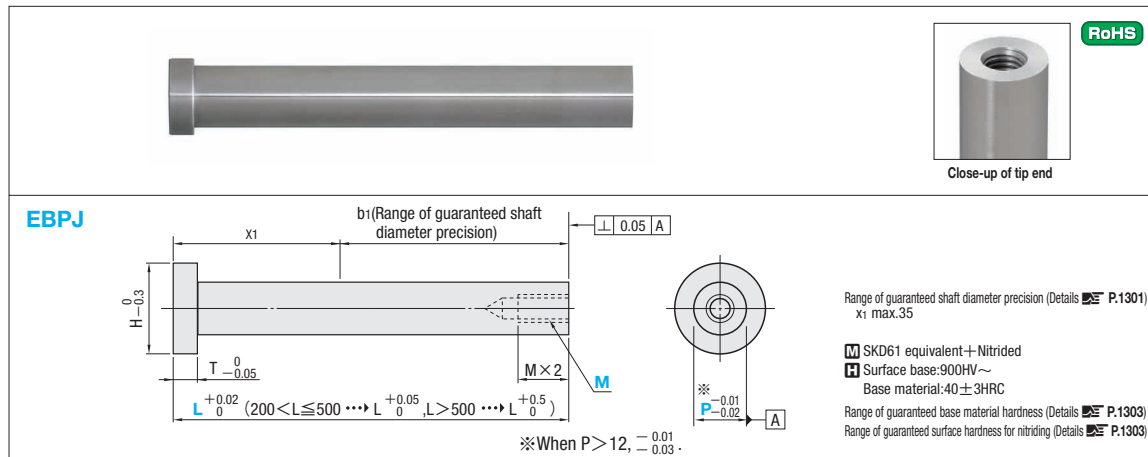

H	T	Part Number		L 0.01mm increments (L>500 → 0.1mm increments)	M
		Type	P		
10	6	EBPJ	6	40.00~450.00	3 4 5 6 8 10 12 16 Ⓜ M≤P-3
11			7		
13			8		
15			10		
17			12		
21			16		
25	8	EBPJ	20	40.00~800.00	

Order **Part Number** — **L** — **M**
EBPJ8 — 220.00 — M4

Days to Ship **Quotation**

Alterations **Part Number** — **L** — **M** — (KC · WKC...etc.)
EBPJ8 — 225.55 — M4 — WKC4

Alterations	Code	Spec.	1Code
	KC	Single flat cutting P/2 ≤ KC < H/2	
	WKC	Two flats cutting P/2 ≤ WKC < H/2	
	KAC KBC	Varied width parallel flats cutting P/2 ≤ KAC < H/2 KBC=0.1mm increments only KAC < KBC < H/2	
	RKC	Two flats (right angled) cutting P/2 ≤ RKC < H/2	
	DKC	Three flats cutting P/2 ≤ DKC < H/2	
	SKC	Four flats cutting P/2 ≤ SKC < H/2	
	KGC	Two flats (angled) cutting P/2 ≤ KGC < H/2 AG=1° increments 0 < AG < 360	
	KTC	Three flats cutting at 120° P/2 ≤ KTC < H/2	

Alteration details [P.53](#)

Alterations	Code	Spec.	1Code
	HC	HC=0.1mm increments Ⓜ P+1 ≤ HC < H	
	TC	TC=0.1mm increments Ⓜ T/2 ≤ TC < T (Dimension L remains unchanged) Ⓜ T-TC ≤ Lmax.-L	
	NC	Dowel hole boring Ⓜ Combination with other than NHC · NHN not available.	
	NCW	Dowel hole boring+Spring pin driving Ⓜ Combination with other than NHC · NHN not available.	
	NCS	Dowel hole boring+Dowel pin driving Ⓜ Combination with other than NHC · NHN not available.	
	NHC	Numbering on the head How to order P.54 Ⓜ Combination with SKC · MC not available.	
	NHN	Automatic sequential numbering on the head How to order P.54 Ⓜ Combination with SKC · MC not available.	
	MC	Head tapping Ⓜ Available when P ≥ 8 Ⓜ Combination with any other alteration not available.	

P Price **Quotation**

ex Example

Characteristics

- The assembly and adjustment of ejector block (stripper plate) ejected mold is easy.
- The ejector blocks can be installed from the parting line by using socket head cap screws.
- The rotation during bolt tightening can be prevented by combination with key flat cutting alteration (KC, etc.).
- They are used by customers of food containers, medical apparatuses, cylindrical molded products, automotive interior decoration products and home appliances, etc.

Example of use on cylindrical containers

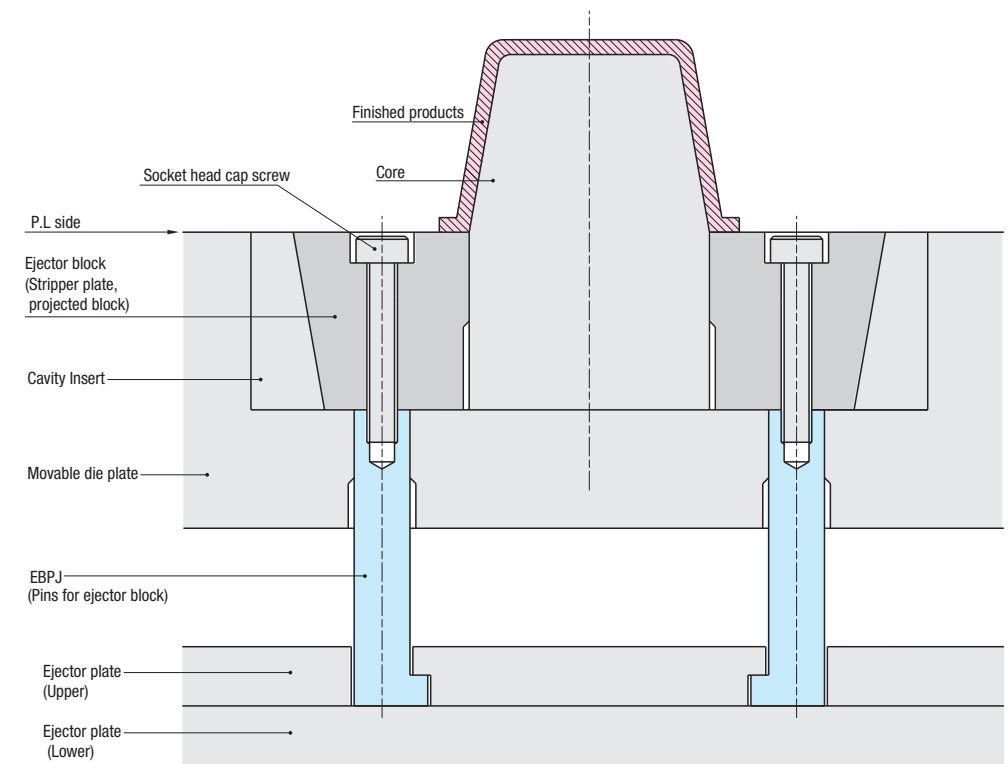

Straight Ejector Pins

Dies Steel SKD61 equivalent + Nitriding