

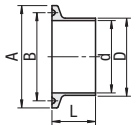

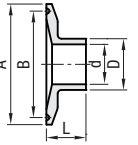





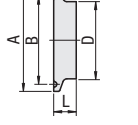

# Sanitary Pipe Fittings

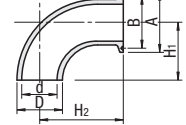
## Ferrule x Welded

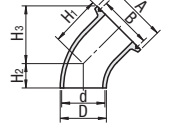
 <p>RoHS10</p>	<table border="1"> <tr><th>Type</th><th>Material</th></tr> <tr><td>SNFR</td><td>304 Stainless Steel</td></tr> <tr><td>SNFRS</td><td>316 Stainless Steel</td></tr> </table>	Type	Material	SNFR	304 Stainless Steel	SNFRS	316 Stainless Steel	
	Type	Material						
SNFR	304 Stainless Steel							
SNFRS	316 Stainless Steel							
<table border="1"> <tr><th>Type</th><th>Material</th></tr> <tr><td>SNFRE</td><td>304 Stainless Steel</td></tr> </table>	Type	Material	SNFRE	304 Stainless Steel				
Type	Material							
SNFRE	304 Stainless Steel							
 <p>RoHS10</p>	<table border="1"> <tr><th>Type</th><th>Material</th></tr> <tr><td>SNFK</td><td>304 Stainless Steel</td></tr> </table>	Type	Material	SNFK	304 Stainless Steel			
Type	Material							
SNFK	304 Stainless Steel							
 <p>RoHS10</p>	<table border="1"> <tr><th>Type</th><th>Material</th></tr> <tr><td>SNFE</td><td>304 Stainless Steel</td></tr> <tr><td>SNFES</td><td>316 Stainless Steel</td></tr> </table>	Type	Material	SNFE	304 Stainless Steel	SNFES	316 Stainless Steel	
Type	Material							
SNFE	304 Stainless Steel							
SNFES	316 Stainless Steel							
 <p>RoHS10</p>	<table border="1"> <tr><th>Type</th><th>Material</th></tr> <tr><td>SNFHE</td><td>304 Stainless Steel</td></tr> <tr><td>SNFHES</td><td>316 Stainless Steel</td></tr> </table>	Type	Material	SNFHE	304 Stainless Steel	SNFHES	316 Stainless Steel	
Type	Material							
SNFHE	304 Stainless Steel							
SNFHES	316 Stainless Steel							
 <p>RoHS10</p>	<table border="1"> <tr><th>Type</th><th>Material</th></tr> <tr><td>SNFRD</td><td>304 Stainless Steel</td></tr> <tr><td>SNFRDS</td><td>316 Stainless Steel</td></tr> </table>	Type	Material	SNFRD	304 Stainless Steel	SNFRDS	316 Stainless Steel	
Type	Material							
SNFRD	304 Stainless Steel							
SNFRDS	316 Stainless Steel							
 <p>RoHS10</p>	<table border="1"> <tr><th>Type</th><th>Material</th></tr> <tr><td>SNFRY</td><td>304 Stainless Steel</td></tr> <tr><td>SNFRYS</td><td>316 Stainless Steel</td></tr> </table>	Type	Material	SNFRY	304 Stainless Steel	SNFRYS	316 Stainless Steel	
Type	Material							
SNFRY	304 Stainless Steel							
SNFRYS	316 Stainless Steel							

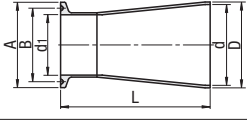
Part Number		D	d	A	B	L
Type	No.					
SNFRS	8A	13.8	10.5	34.0	27.5	17.0
	10A	17.3	14.0			
	15A	21.7	17.5			
SNFR	1S	25.4	23.0	50.5	43.5	21.0
	1.5S	38.1	35.7	50.5	43.5	
	2S	50.8	47.8	64.0	56.5	
	2.5S	63.5	59.5	77.5	70.5	
	3S	76.3	72.3	91.0	83.5	

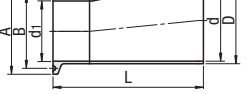
Part Number		Nominal	D	d	A	B	L
Type	No.						
SNFRE	1S	8A	13.8	10.5	50.5	43.5	21.0
		10A	17.3	11.3			
		15A	21.7	15.7			
SNFRE	1.5S	10A	17.3	11.3	50.5	43.5	21.0
		15A	21.7	15.7			
		20A	27.2	21.2			
	2S	15A	21.7	15.7			
		20A	27.2	21.2			
SNFRE	2.5S	25A	34.0	28.4	64.0	56.5	21.0
		20A	27.2	21.2			
		25A	34.0	28.4			
		32A	42.7	37.1			
		25A	34.0	28.4			
SNFRE	3S	32A	42.7	37.1	91.0	83.5	21.0
		40A	48.6	43.0			

Part Number		D	d	A	B
Type	No.				
SNFK	1S	38.1	50.5	43.5	11.0
	1.5S				
	2S				
	2.5S				
	3S				

○ SNFK1S and 1.5S are the same shape.

Part Number		D	d	A	B	H <sub>1</sub>	H <sub>2</sub>
Type	No.						
SNFE	1S	25.4	23	50.5	43.5	34	55
	1.5S	38.1	35.7	50.5	43.5	49	70
	2S	50.8	47.8	64.0	56.5	61	82
	2.5S	63.5	59.5	77.5	70.5	84	105
	3S	76.3	72.3	91.0	83.5	89	110

Part Number		D	d	A	B	H <sub>1</sub>	H <sub>2</sub>	H <sub>3</sub>
Type	No.							
SNFHE	1S	25.4	23	50.5	43.4	36.8	15.8	43.9
	1.5S	38.1	35.7	50.5	43.4	44.7	23.7	49.5
	2S	50.8	47.8	64.0	56.4	52.6	31.6	59.8
	2.5S	63.5	59.5	77.5	70.4	63.0	42.0	71.9
	3S	76.3	72.3	91.0	83.4	73.6	52.6	84.2

Part Number		D	d	d <sub>1</sub>	A	B	L
Type	No.						
SNFRD	1.5S	38.1	35.7	23	50.5	43.4	88
	2S	50.8	47.8	35.7	50.5	43.4	
	2.5S	63.5	59.5	47.8	64.0	56.4	
	3S	76.3	72.3	59.5	77.5	70.4	

○ The ferrule is one size smaller. Ex.: For No.2S, 2S (pipe) x 1.5S(ferrule part)

Part Number		D	d	d <sub>1</sub>	A	B	L
Type	No.						
SNFRY	1.5S	38.1	35.7	23	50.5	43.4	88
	2S	50.8	47.8	35.7	50.5	43.4	
	2.5S	63.5	59.5	47.8	64.0	56.4	
	3S	76.3	72.3	59.5	77.5	70.4	











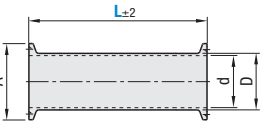

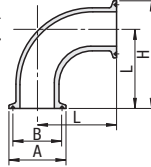
○ The ferrule is one size smaller. Ex.: For No.2S, 2S (pipe) x 1.5S(ferrule part)

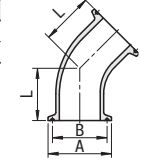
Part Number Example: SNFR2S - SNFRE3S - 32A

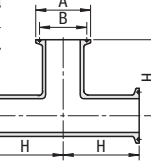
Application Example: Gasket, Ferrule, Clamp

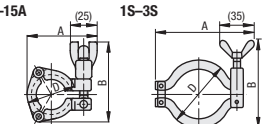
# Sanitary Pipe Fittings

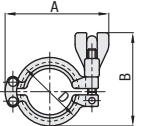
## Double Ferrules / Clamp / Gasket

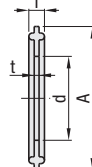
 <p>RoHS10</p>	<table border="1"> <tr><th>Type</th><th>Material</th></tr> <tr><td>SNPAA</td><td>304 Stainless Steel</td></tr> </table>	Type	Material	SNPAA	304 Stainless Steel						
	Type	Material									
SNPAA	304 Stainless Steel										
 <p>RoHS10</p>	<table border="1"> <tr><th>Type</th><th>Material</th></tr> <tr><td>SNBE</td><td>304 Stainless Steel</td></tr> <tr><td>SNBES</td><td>316 Stainless Steel</td></tr> </table>	Type	Material	SNBE	304 Stainless Steel	SNBES	316 Stainless Steel				
Type	Material										
SNBE	304 Stainless Steel										
SNBES	316 Stainless Steel										
 <p>RoHS10</p>	<table border="1"> <tr><th>Type</th><th>Material</th></tr> <tr><td>SNBHE</td><td>304 Stainless Steel</td></tr> <tr><td>SNBHES</td><td>316 Stainless Steel</td></tr> </table>	Type	Material	SNBHE	304 Stainless Steel	SNBHES	316 Stainless Steel				
Type	Material										
SNBHE	304 Stainless Steel										
SNBHES	316 Stainless Steel										
 <p>RoHS10</p>	<table border="1"> <tr><th>Type</th><th>Material</th></tr> <tr><td>SNBT</td><td>304 Stainless Steel</td></tr> <tr><td>SNBTS</td><td>316 Stainless Steel</td></tr> </table>	Type	Material	SNBT	304 Stainless Steel	SNBTS	316 Stainless Steel				
Type	Material										
SNBT	304 Stainless Steel										
SNBTS	316 Stainless Steel										
 <p>RoHS10</p>	<table border="1"> <tr><th>Type</th><th>Material</th><th>Recommended Operating Pressure</th></tr> <tr><td rowspan="2">SNCP</td><td>8A-15A CF-8 Stainless Steel Cast</td><td>8A-2S: 0-0.3 MPa</td></tr> <tr><td>1S-3S 304 Stainless Steel</td><td>2.5S or 3S: 0-0.2 MPa</td></tr> </table>	Type	Material	Recommended Operating Pressure	SNCP	8A-15A CF-8 Stainless Steel Cast	8A-2S: 0-0.3 MPa	1S-3S 304 Stainless Steel	2.5S or 3S: 0-0.2 MPa		
Type	Material	Recommended Operating Pressure									
SNCP	8A-15A CF-8 Stainless Steel Cast	8A-2S: 0-0.3 MPa									
	1S-3S 304 Stainless Steel	2.5S or 3S: 0-0.2 MPa									
 <p>RoHS10</p>	<table border="1"> <tr><th>Type</th><th>Material</th><th>Recommended Operating Pressure</th></tr> <tr><td>SNCPH</td><td>CF-8 Stainless Steel Cast</td><td>1S-2S: 0-1 MPa</td></tr> <tr><td></td><td></td><td>2.5S-3S: 0-0.8 MPa</td></tr> </table>	Type	Material	Recommended Operating Pressure	SNCPH	CF-8 Stainless Steel Cast	1S-2S: 0-1 MPa			2.5S-3S: 0-0.8 MPa	
Type	Material	Recommended Operating Pressure									
SNCPH	CF-8 Stainless Steel Cast	1S-2S: 0-1 MPa									
		2.5S-3S: 0-0.8 MPa									
 <p>RoHS10</p>	<table border="1"> <tr><th>Type</th><th>Material</th></tr> <tr><td>SNGS</td><td>Silicon</td></tr> <tr><td>SNGSF</td><td>PTFE</td></tr> </table>	Type	Material	SNGS	Silicon	SNGSF	PTFE				
Type	Material										
SNGS	Silicon										
SNGSF	PTFE										

Part Number		L Selection	D	d	A
Type	No.				
SNPAA	1S	100	25.4	23	50.5
	1.5S	150			
	2S	200	38.1	35.7	50.5
		250			
	300	50.8	47.8	64	

Part Number		A	B	L	H
Type	No.				
SNBES	8A	34.0	27.5	55	72
	10A				
	15A				
SNBE	1S	50.5	43.5	55	80.3
	1.5S	50.5	43.5	70	95.3
	2S	64.0	56.5	82	114
	2.5S	77.5	70.5	105	143.8
	3S	91.0	83.5	110	155.5

Part Number		A	B	L
Type	No.			
SNBHE	1S	50.5	43.4	36.8
	1.5S	50.5	43.4	44.7
	2S	64.0	56.4	52.6
	2.5S	77.5	70.4	63.0
	3S	91.0	83.4	73.6

Part Number		A	B	H
Type	No.			
SNBTS	8A	34.0	27.5	55
	10A			
	15A			
SNBT	1S	50.5	43.5	55
	1.5S	50.5	43.5	70
	2S	64.0	56.5	82
	2.5S	77.5	70.5	105
	3S	91.0	83.5	110

Part Number		D	A	B
Type	No.			
SNCP	8A	45	65	74
	10A			
	15A			
	1S	60	94	90
	1.5S	60	94	90
	2S	75	110	103
	2.5S	90	130	108
3S	104	144	114	

○ As the ferrule shape for No.8A-15A and 1S and 1.5S are identical, the shapes for SNCP8A-15A and SNCP1S, 1.5S are identical.

Part Number		D	A	B
Type	No.			
SNCPH	1S	65	97	88
	1.5S			
	2S			
	2.5S			
	3S			

○ The shapes for SNCPH1S and 1.5S are identical.

Part Number		A	d	t	t
Type	No.				
SNGSF	8A	34.0	10.5	4.9	1.7
	10A		14		
	15A		17.5		
SNGS	1S	50.5	23.2 (23)	5.5 (5.0)	2 (1.8)
	1.5S		35.9 (35.7)		
	2S		48 (47.8)		
	2.5S		59.7 (59.5)		
	3S		72.5 (72.3)		

○ Dimensions in ( ) are for SNGSF.

Part Number Example: SNPAA1S - SNBES8A - SNBTD2S-1S

Application Example: Gasket (SNGS P.3431), Ferrule, Clamp (SNCP P.3431)