

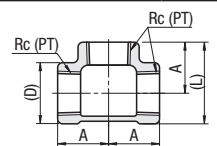







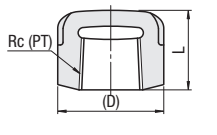

Low Pressure Steel Pipe Fittings (Equal Size Pipe Threads)

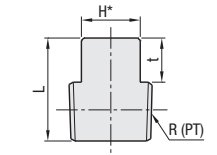
Tees / Caps / Plug / Round Nipples / Double Long Nipples / Hexagon Nipples

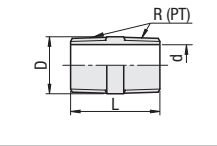
 <p>RoHS 10</p>	<table border="1"> <tr><th>Type</th><th>Material</th><th>Surface Treatment</th></tr> <tr><td>SGPPT</td><td>FCMB270</td><td>Hot Zinc Plating</td></tr> <tr><td>SUTPT</td><td>CF-8 Stainless Steel Cast</td><td>—</td></tr> </table> 	Type	Material	Surface Treatment	SGPPT	FCMB270	Hot Zinc Plating	SUTPT	CF-8 Stainless Steel Cast	—			
Type	Material	Surface Treatment											
SGPPT	FCMB270	Hot Zinc Plating											
SUTPT	CF-8 Stainless Steel Cast	—											
 <p>RoHS 10</p>	<table border="1"> <tr><th>Type</th><th>Material</th><th>Surface Treatment</th></tr> <tr><td>SGPPC</td><td>FCMB270</td><td>Hot Zinc Plating</td></tr> <tr><td>SUTPC</td><td>CF-8 Stainless Steel Cast</td><td>—</td></tr> </table> 	Type	Material	Surface Treatment	SGPPC	FCMB270	Hot Zinc Plating	SUTPC	CF-8 Stainless Steel Cast	—			
Type	Material	Surface Treatment											
SGPPC	FCMB270	Hot Zinc Plating											
SUTPC	CF-8 Stainless Steel Cast	—											
 <p>RoHS 10</p>	<table border="1"> <tr><th>Type</th><th>Material</th><th>Surface Treatment</th></tr> <tr><td>SGPPP</td><td>SWCH10R Equiv.</td><td>Trivalent Chromate</td></tr> <tr><td>SUPPP</td><td>CF-8 Stainless Steel Cast</td><td>—</td></tr> </table> 	Type	Material	Surface Treatment	SGPPP	SWCH10R Equiv.	Trivalent Chromate	SUPPP	CF-8 Stainless Steel Cast	—			
Type	Material	Surface Treatment											
SGPPP	SWCH10R Equiv.	Trivalent Chromate											
SUPPP	CF-8 Stainless Steel Cast	—											
 <p>RoHS 10</p>	<table border="1"> <tr><th>Type</th><th>Material</th><th>Surface Treatment</th></tr> <tr><td>SGPNP</td><td>SGP</td><td>Hot Zinc Plating</td></tr> <tr><td>SUTNP</td><td>304 Stainless Steel</td><td>—</td></tr> </table> 	Type	Material	Surface Treatment	SGPNP	SGP	Hot Zinc Plating	SUTNP	304 Stainless Steel	—			
Type	Material	Surface Treatment											
SGPNP	SGP	Hot Zinc Plating											
SUTNP	304 Stainless Steel	—											
 <p>RoHS 10</p>	<table border="1"> <tr><th>Type</th><th>Material</th><th>Surface Treatment</th></tr> <tr><td>SGPNPR</td><td>SGP</td><td>Hot Zinc Plating</td></tr> <tr><td>SUTNPR</td><td>304 Stainless Steel</td><td>—</td></tr> </table> 	Type	Material	Surface Treatment	SGPNPR	SGP	Hot Zinc Plating	SUTNPR	304 Stainless Steel	—			
Type	Material	Surface Treatment											
SGPNPR	SGP	Hot Zinc Plating											
SUTNPR	304 Stainless Steel	—											
 <p>RoHS 10</p>	<table border="1"> <tr><th>Type</th><th>Material</th><th>Surface Treatment</th></tr> <tr><td>SGPNR</td><td>FCMB270</td><td>Hot Zinc Plating</td></tr> <tr><td>SUTNR</td><td>CF-8 Stainless Steel Cast</td><td>—</td></tr> <tr><td>SUTNRS</td><td>CF-8M Stainless Steel Cast</td><td>—</td></tr> </table> 	Type	Material	Surface Treatment	SGPNR	FCMB270	Hot Zinc Plating	SUTNR	CF-8 Stainless Steel Cast	—	SUTNRS	CF-8M Stainless Steel Cast	—
Type	Material	Surface Treatment											
SGPNR	FCMB270	Hot Zinc Plating											
SUTNR	CF-8 Stainless Steel Cast	—											
SUTNRS	CF-8M Stainless Steel Cast	—											

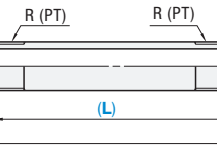
Operating Conditions of Fittings

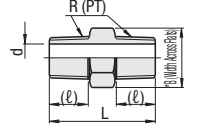
Fluid State	Max. Operating Pressure (MPa)
Steam / Air / Gas / Oil: Up to 300°C	1.0
Steam / Air / Oil / Pulsating Water: Up to 200°C	1.4
Static Flow Water: Up to 120°C	2.0

Part Number Example: **SGPPT8A** - L

Part Number Example: **SGPNR8A** - L

Part Number Example: **SGPNR8A** - 75

*Pulsating Water is a stream of water that is generated under steady operating conditions and variation of pressure and flow rate occurs in cycles. (Except for transitional change).
 *Static Flow Water is a non-pulsating stream of water.
 *As fittings are cast products, () dimensions such as (D) and (L2) are for reference, not guaranteed.

Part Number	Rc (PT)	(D)	(L)	A	(D)	(L)	A
Type		SGPPT			SUTPT		
No.							
6A	1/8	15	24.5	17	18	28	19
8A	1/4	19	28.5	19	22	30	19
10A	3/8	23	34.5	23	26	36	23
15A	1/2	27	40.5	27	30	42	27
20A	3/4	33	48.5	32	36	50	32
25A	1	41	58.5	38	44	60	38
32A	1 1/4	50	71	46	53	72.5	46
40A	1 1/2	56	76	48	60	78	48
50A	2	69	91.5	57	73	93.5	57

Part Number	Rc (PT)	(D)	L	(D)	L
Type		SGPPC		SUTPC	
No.					
6A	1/8	19	14	18	16
8A	1/4	22	15	22	18
10A	3/8	23	17	26	20
15A	1/2	27	20	30	21
20A	3/4	33	24	36	24
25A	1	41	28	44	28
32A	1 1/4	50	30	53	30
40A	1 1/2	56	32	60	32
50A	2	69	36	73	36

Part Number	R (PT)	Square Size H	t	L	
Type				SGPPP	SUPPP
No.					
6A	1/8	7	7	16	16
8A	1/4	9	8	19	19
10A	3/8	12	9	21	21
15A	1/2	14	10	26	25
20A	3/4	17	11	29	28
25A	1	19	12	31	31
32A	1 1/4	23	13	35	35
40A	1 1/2	26	14	36	36
50A	2	32	15	41	41

* Shape of H Part: No.6A-50A = Square

Part Number	R (PT)	D	L	d	
Type				SGPNP	SUTNP
No.					
6A	1/8	10.5	24	6.5	6.5
8A	1/4	13.8	26	8.7	9.7
10A	3/8	17.3	28	12.1	13.1
15A	1/2	21.7	34	15.8	15.5
20A	3/4	27.2	38	21.6	21.3
25A	1	34.0	42	27.8	28.1
32A	1 1/4	42.7	50	35.9	35.8
40A	1 1/2	48.6	50	41.9	41.8
50A	2	60.5	58	53.2	53.6

Part Number	(L)	R (PT)	(D)	(d)	Available Types												
Type						SGPNPR						SUTNPR					
No.						L50	L75	L100	L125	L50	L75	L100	L125	L50	L75	L100	L125
6A	50	1/8	10.5	—	6.2	—	—	—	—	—	—	—	—	—	—	—	
8A	75	1/4	13.4	13.8	9.2	9.4	—	—	—	—	—	—	—	—	—	—	
10A	100	3/8	17.4	17.3	12.9	12.7	—	—	—	—	—	—	—	—	—	—	
15A	125	1/2	21.9	21.7	16.5	16.1	—	—	—	—	—	—	—	—	—	—	
20A	—	3/4	27.2	27.2	21.5	21.4	—	—	—	—	—	—	—	—	—	—	

* The dimension D of SGPNPR has a tolerance of +0.5 mm.









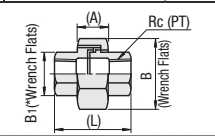

Part Number	R (PT)	B	L	(L)	d	Available Types											
Type						SGPNR				SUTNR				SUTNRS			
No.						1-9	10-29	1-19	20-49	1-19	20-49	1-19	20-49	1-9	10-29	1-19	20-49
6A	1/8	14	32	32	11	11	5	5	5	—	—	—	—	—	—	—	
8A	1/4	17	34	34	12.5	13.5	7	7	6.8	—	—	—	—	—	—	—	
10A	3/8	21	36	36	13	13.5	9	9	9	—	—	—	—	—	—	—	
15A	1/2	26	43	42	16.5	18	13	13	13.2	—	—	—	—	—	—	—	
20A	3/4	32	48	47	18.5	19.5	18	16	15.8	—	—	—	—	—	—	—	
25A	1	38	52	52	20.5	20.5	24	22	21.7	—	—	—	—	—	—	—	
32A	1 1/4	46	56	56	22.5	22.5	32	30	30.1	—	—	—	—	—	—	—	
40A	1 1/2	54	60	60	23.5	23.5	37	35	—	—	—	—	—	—	—	—	
50A	2	63	66	66	25.5	25.5	48	47	—	—	—	—	—	—	—	—	

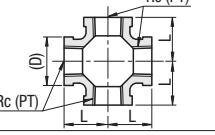
* Shape of B Part: No.6A-40A=Hex, 50A=Octagon ○ SUTNRS is not available for part type No. 40A and 50A.

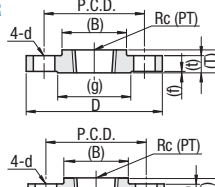
Low Pressure Steel Pipe Fittings (Equal Size Pipe Threads)

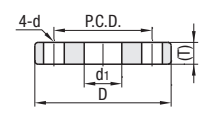
Unions / Cross / Flange / Flange for Welding / Blind Flanged for Welding / 3-Way Elbow

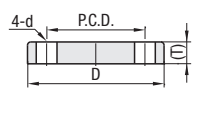
Feature: These fittings can be removed by loosening the nuts, and thus, require no twist of pipes themselves.

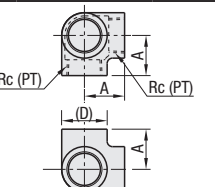
 <p>RoHS 10</p>	<table border="1"> <tr><th>Type</th><th>Material</th><th>Surface Treatment</th></tr> <tr><td>SGPPU</td><td>FCMB270</td><td>Hot Zinc Plating</td></tr> <tr><td>SUTPU</td><td>CF-8 Stainless Steel Cast</td><td>—</td></tr> </table> 	Type	Material	Surface Treatment	SGPPU	FCMB270	Hot Zinc Plating	SUTPU	CF-8 Stainless Steel Cast	—
Type	Material	Surface Treatment								
SGPPU	FCMB270	Hot Zinc Plating								
SUTPU	CF-8 Stainless Steel Cast	—								
 <p>RoHS 10</p>	<table border="1"> <tr><th>Type</th><th>Material</th><th>Surface Treatment</th></tr> <tr><td>SGPCS</td><td>FCMB270</td><td>Hot Zinc Plating</td></tr> <tr><td>SUTCS</td><td>CF-8 Stainless Steel Cast</td><td>—</td></tr> </table> 	Type	Material	Surface Treatment	SGPCS	FCMB270	Hot Zinc Plating	SUTCS	CF-8 Stainless Steel Cast	—
Type	Material	Surface Treatment								
SGPCS	FCMB270	Hot Zinc Plating								
SUTCS	CF-8 Stainless Steel Cast	—								
 <p>RoHS 10</p>	<table border="1"> <tr><th>Type</th><th>Material</th><th>Surface Treatment</th></tr> <tr><td>SGPFR</td><td>FCMB270</td><td>Hot Zinc Plating</td></tr> <tr><td>SUTFR</td><td>CF-8 Stainless Steel Cast</td><td>—</td></tr> </table> 	Type	Material	Surface Treatment	SGPFR	FCMB270	Hot Zinc Plating	SUTFR	CF-8 Stainless Steel Cast	—
Type	Material	Surface Treatment								
SGPFR	FCMB270	Hot Zinc Plating								
SUTFR	CF-8 Stainless Steel Cast	—								
 <p>RoHS 10</p>	<table border="1"> <tr><th>Type</th><th>Material</th></tr> <tr><td>SGPFRW</td><td>1018 Carbon Steel or Equivalent</td></tr> <tr><td>SUTFRW</td><td>304 Stainless Steel</td></tr> </table> 	Type	Material	SGPFRW	1018 Carbon Steel or Equivalent	SUTFRW	304 Stainless Steel			
Type	Material									
SGPFRW	1018 Carbon Steel or Equivalent									
SUTFRW	304 Stainless Steel									
 <p>RoHS 10</p>	<table border="1"> <tr><th>Type</th><th>Material</th></tr> <tr><td>SGPFRB</td><td>1018 Carbon Steel or Equivalent</td></tr> <tr><td>SUTFRB</td><td>304 Stainless Steel</td></tr> </table> 	Type	Material	SGPFRB	1018 Carbon Steel or Equivalent	SUTFRB	304 Stainless Steel			
Type	Material									
SGPFRB	1018 Carbon Steel or Equivalent									
SUTFRB	304 Stainless Steel									
 <p>RoHS 10</p>	<table border="1"> <tr><th>Type</th><th>Material</th><th>Surface Treatment</th></tr> <tr><td>SGSTL</td><td>FCMB270</td><td>Hot Zinc Plating</td></tr> </table> 	Type	Material	Surface Treatment	SGSTL	FCMB270	Hot Zinc Plating			
Type	Material	Surface Treatment								
SGSTL	FCMB270	Hot Zinc Plating								

Part Number	Rc (PT)	B ₁	(L)	(A)	B	B ₁	(L)	(A)	B
Type		SGPPU			SUTPU				
No.									
6A	1/8	15	30	13	25	14	30	13	25
8A	1/4	19	33.5	13.5	31	18	33.5	13.5	31
10A	3/8	23	38	16	37	22	37.5	16	37
15A	1/2	27	41	17	42	26	40.5	17	42
20A	3/4	33	51	18.5	49	32	42.5	17	50
25A	1	41	54	20	59	41	51	20	59

* Shape of B₁ Part: SUTPU6A / 8A: 2-Flat / SUTPU10A, 15A: Hex / SUTPU20A / 25A: Octagon / SGPPU: Octagon

Part Number	Rc (PT)	(D)	L	(D)	L
Type		SGPCS		SUTCS	
No.					
8A	1/4	19	19	22	19
10A	3/8	23	23	26	23
15A	1/2	27	27	30	27
20A	3/4	33	32	36	32
25A	1	41	38	44	38

Part Number	Rc (PT)	D	(T)	(t)	(B)	(f)	(g)	P.C.D.	d	Applicable Bolt Diameter
Type										
No.										
15A	1/2	95	18	12	38	1	51	70	15	M12
20A	3/4	100	19	14	42	1	56	75	15	M12
25A	1	125	23	14	49	1	67	90	19	M16
32A	1 1/4	135	25	16	64	2	76	100	19	M16
40A	1 1/2	140	25	16	68	2	81	105	19	M16
50A	2	155	29	16	82	2	96	120	19	M16

Part Number	Rc (PT)	D	(T)	(t)	(B)	P.C.D.	d	Applicable Bolt Diameter
Type								
No.								
15A	1/2	95	16	12	30	70	15	M12
20A	3/4	100	20	14	36	75	15	M12
25A	1	125	20	14	44	90	19	M16
32A	1 1/4	135	22	16	53	100	19	M16
40A	1 1/2	140	24	16	60	105	19	M16
50A	2	155	24	16	73	120	19	M16

Part Number	D	(T)	P.C.D.	d	d ₁	Applicable Bolt Diameter
Type						
No.						
10A	90	12	65	15	17.8	M12
15A	95	12	70	15	22.2	M12
20A	100	14	75	15	27.7	M12
25A	125	14	90	19	34.5	M16

Part Number	D	(T)	P.C.D.	d	Applicable Bolt Diameter
Type					
No.					
10A	90	12	65	15	M12

Low Pressure Steel Pipe Fittings (With Seal Coating)

Female / Male Elbow / Plug / Round Nipples / Hexagon Nipples / Bushings

Feature: Male threads are coated. Provides immediate out of the box operation.

Low Pressure Steel Pipe Fittings – Female / Male Elbow	Type	Material	Surface Treatment
	SGCEL	FCMB270	Hot Zinc Plating
	SUCEL	CF-8 Stainless Steel Cast	—

⊕ Allowable temperature: 150°C

Low Pressure Steel Pipe Fittings – Plug	Type	Material	Surface Treatment
	SGCPP	FCMB270	Hot Zinc Plating
	SUCPP	CF-8 Stainless Steel Cast	—

⊕ Allowable temperature: 150°C

Low Pressure Steel Pipe Fittings – Round Nipples	Type	Material	Surface Treatment
	SGCNP	SGP	Hot Zinc Plating
	SUCNP	304 Stainless Steel	—

⊕ Allowable temperature: 150°C

Low Pressure Steel Pipe Fittings – Hexagon Nipples	Type	Material	Surface Treatment
	SGCNR	FCMB270	Hot Zinc Plating
	SUCNR	CF-8 Stainless Steel Cast	—

⊕ Allowable temperature: 150°C

Low Pressure Steel Pipe Fittings – Bushings	Type	Material	Surface Treatment
	SGCPB	FCMB270	Hot Zinc Plating
	SUCPB	CF-8 Stainless Steel Cast	—

⊕ Allowable temperature: 150°C

Part Number	R Rc (PT)	(D)	(L ₁)	(L ₂)	A	B	(D)	(L ₁)	(L ₂)	A	B	
SGCEL SUCEL	6A	1/8	19	23	36	17	26	14.5	22	33	17	26
	8A	1/4	22	26	42	19	30	21	26	41	19	30
	10A	3/8	27	31	48	23	35	25	32	48	23	35
	15A	1/2	31	38	56	27	40	29	38	55	27	40
	20A	3/4	36	45	66	32	47	36	46	65	32	47
	25A	1	45	55	76.5	38	54	44	55	76	38	54

Part Number	R (PT)	Square Size H	t	L		
SGCPP SUCPP	6A	1/8	7	7	16	16
	8A	1/4	9	8	19	19
	10A	3/8	12	9	21	21
	15A	1/2	14	10	26	25
	20A	3/4	17	11	29	28
	25A	1	19	12	31	31

Part Number	R (PT)	D	L	d		
SGCNP SUCNP	6A	1/8	10.5	24	6.5	6.5
	8A	1/4	13.8	26	8.7	9.7
	10A	3/8	17.3	28	12.1	13.1
	15A	1/2	21.7	34	15.8	15.5
	20A	3/4	27.2	38	21.6	21.3
	25A	1	34	42	27.8	28.1

Part Number	R (PT)	B	L		(ℓ)	d			
SGCNR SUCNR	8A	1/4	17	34	34	12.5	12	7	7
	10A	3/8	21	36	36	13	13	9	9
	15A	1/2	26	43	42	16.5	16	13	13
	20A	3/4	32	48	47	18.5	18	18	16
	25A	1	38	52	52	20	20	24	22

Part Number	Rc (PT)	R (PT)	L	B	
SGCPB SUCPB	12	1/8	1/4	17	17
	13	1/8	3/8	18	21
	23	1/4	3/8	18	21
	24	1/4	1/2	21	26
	34	3/8	1/2	21	26
	36	3/8	3/4	24	32
	46	1/2	3/4	24	32

CAUTIONS

- Not applicable to steam plumbing.
- Once fittings are used, the function of the thread coating resin is impaired. Thus, wrap seal tape around fittings before use.

Part Number Example **SGCEL25A**
Part Number **SGCPP20A**

Low Pressure Steel Pipe Fittings (Equal Size Pipe Threads)

Socket / Parallel Tapped (PS) Socket / Long Sockets / Elbow / 45° Elbow / Female / Male Elbow

Low Pressure Steel Pipe Fittings – Socket	Type	Material	Surface Treatment
	SGPPS	FCMB270	Hot Zinc Plating
	SUTPS	304 Stainless Steel	—
	SUTPSS	316 Stainless Steel	—

*Only SGPPS has claws on the circumference.

RoHS 10

Low Pressure Steel Pipe Fittings – Parallel Tapped (PS) Socket	Type	Material	Surface Treatment
	SGPRP	Carbon Steel Pipes	Zinc Electroplating
	SUTRP	304 Stainless Steel	—

RoHS 10

Low Pressure Steel Pipe Fittings – Long Sockets	Type	Material	Surface Treatment
	SUTPSR	304 Stainless Steel	—
	No. 6A, 8A, 10A-75		

Other Than Above

RoHS 10

Low Pressure Steel Pipe Fittings – Elbow	Type	Material	Surface Treatment
	SGPPE	FCMB270	Hot Zinc Plating
	SUTPE	CF-8 Stainless Steel Cast	—
	SUTPES	CF-8M Stainless Steel Cast	—

RoHS 10

Low Pressure Steel Pipe Fittings – 45° Elbow	Type	Material	Surface Treatment
	SGPHE	FCMB270	Hot Zinc Plating
	SUTHE	CF-8 Stainless Steel Cast	—

RoHS 10

Low Pressure Steel Pipe Fittings – Female / Male Elbow	Type	Material	Surface Treatment
	SGPEL	FCMB270	Hot Zinc Plating
	SUTPEL	CF-8 Stainless Steel Cast	—

RoHS 10

Part Number Example **SGPPT8A**
SGPNR8A - 75

Part Number	Rc (PT)	(D)	L	(D ₁)	(ℓ)	(t)	(D)	L	Available Types						
SGPPS SUTPS SUTPSS	6A	1/8	15	22	19	13	4	15	23	•	•	•	•	•	•
	8A	1/4	19	25	22	17	4	19	29	•	•	•	•	•	•
	10A	3/8	23	30	27	18	5	22	30	•	•	•	•	•	•
	15A	1/2	27	35	31	20	6	27	38	•	•	•	•	•	•
	20A	3/4	33	40	37	24	6	33	40	•	•	•	•	•	•
	25A	1	41	45	46	25	8	40	45	•	•	•	•	•	•
	32A	1 1/4	50	50	54	28	8	49	51	•	•	•	•	•	•
	40A	1 1/2	56	55	61	32	9	55.5	54	•	•	•	•	•	•
	50A	2	69	60	75	34	9	68	64	•	•	•	•	•	•

⊕ SUTPSS is not available for part type No. 6A, 32A, 40A and 50A.

Part Number	Rp (PS)	(D)	(L)	(D)	(L)	
SGPRP SUTRP	6A	1/8	15	19	13.8	20
	8A	1/4	19	27	17	25
	10A	3/8	23	28	21	26
	15A	1/2	28	37	25	33
	20A	3/4	34.5	39	31	36
	25A	1	41.5	46	38	43
32A	1 1/4	51	51	47	48	

Part Number	(L)	Rp (PS)	(D)
SUTPSR	6A	1/8	15
	8A	1/4	19
	10A	3/8	23
	15A	1/2	26.5
	20A	3/4	33

Part Number	Rc (PT)	(D)	L	(A)	(D)	L	(A)	Available Types						
SGPPE SUTPE SUTPES	6A	1/8	15	17	24.5	18	19	28	•	•	•	•	•	•
	8A	1/4	19	19	28.5	22	19	30	•	•	•	•	•	•
	10A	3/8	23	23	35	26	23	36	•	•	•	•	•	•
	15A	1/2	27	27	41	30	27	42	•	•	•	•	•	•
	20A	3/4	33	32	49	36	32	50	•	•	•	•	•	•
	25A	1	41	38	59.5	44	38	60	•	•	•	•	•	•
	32A	1 1/4	50	46	71.5	53	46	72.5	•	•	•	•	•	•
	40A	1 1/2	56	48	76.5	60	48	78	•	•	•	•	•	•
	50A	2	69	57	92	73	57	93.5	•	•	•	•	•	•

⊕ SUTPES is not available for part type No. 32A, 40A and 50A.

Part Number	Rc (PT)	(D)	L	(D)	L	
SGPHE SUTHE	6A	1/8	18	16	17	16
	8A	1/4	22	17	21	17
	10A	3/8	23	19	25	19
	15A	1/2	27	21	28	21
	20A	3/4	33	25	35	25
25A	1	41	29	42	29	

Part Number	R / Rc (PT)	(D)	(L ₁)	(L ₂)	A	B	(D)	(L ₁)	(L ₂)	A	B	
SGPEL SUTPEL	6A	1/8	18	23	35	17	26	14.5	22	33	17	26
	8A	1/4	22	26	41	19	30	19	24.3	39.5	19	30
	10A	3/8	26	31	48	23	35	23	29.8	46.5	23	35
	15A	1/2	30	38	55	27	40	27	35.8	53.5	27	40
	20A	3/4	36	45	65	32	47	33	43.3	63.5	32	47
	25A	1	44	55	76	38	54	41	52.5	74.5	38	54
	32A	1 1/4	53	67	88.5	46	62	50	64	87	46	62
	40A	1 1/2	60	72	98	48	68	56	68.5	96	48	68
	50A	2	73	87	115.5	57	79	69	83	113.5	57	79