

Five-Spoked Handwheels

Five-Spoked Handwheels	Type			Handwheel		Handle		Handle Thread		Included Screw		
	Inner Diameter Shaft Bore Shape	Stationary Handles	Revolving Handles	Without Handle	Material	Surface Treatment	Material	Surface Treatment	Material	Surface Treatment	Material	Surface Treatment
Without Hole	AHLN	AHLNK	AHLN-R	Cast Iron Class No.30	Chrome Plating	1018 Carbon Steel or Equivalent	Chrome Plating	1018 Carbon Steel or Equivalent	Chrome Plating	—	—	—
	AHLNA	AHLNAK	—	Aluminum Casting Alloy 333.0	Shot Blasted	2024 Aluminum Alloy	Shot Blasted					
H8 Hole + Tapped	AHLNM	AHLNKM	—	Cast Iron Class No.30	Chrome Plating	1018 Carbon Steel or Equivalent	Chrome Plating	1018 Carbon Steel or Equivalent	Chrome Plating	—	—	—
H8 Hole + Keyway + Tapped	AHLNKC	AHLNCKC	—	Cast Iron Class No.30	Chrome Plating	1018 Carbon Steel or Equivalent	Chrome Plating					
Square Hole	AHLNW	AHLNKW	—	Aluminum Casting Alloy 333.0	Shot Blasted	2024 Aluminum Alloy	Shot Blasted	1018 Carbon Steel or Equivalent	Chrome Plating	Structural Alloy Steel	Trivalent Chromate	—
Slit	—	AHLND	—	FCD Cast Iron500 Cast Iron (JIS)	Chrome Plating	1018 Carbon Steel or Equivalent	Chrome Plating					

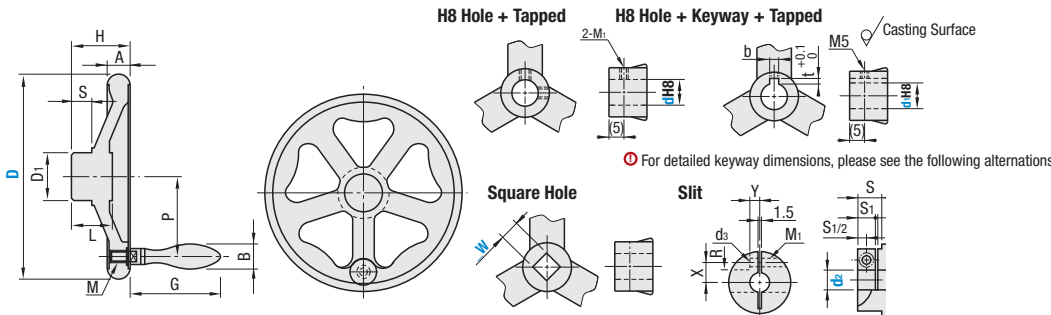

Part Number	Type	D	H	A	D ₁	L	S	M		G		P	Slit						Hex Socket Head Cap Screw		Reference Mass (g)					
								Steel	Aluminum	Stationary	Revolving		d	M ₁ (Coarse)	d ₁	b	t	W Selection	d ₂	S ₁	X	Y	R (Radius)	d ₃	M ₁ (Coarse)	AHLND Reference Tightening Torque (Nm)
Without Hole / Without Handle	AHLN	80	36	14	24	24	5	13	38.5	49	28	10	10	3	1.4	10	*10	9	8	8.5	4.5	4	3	3	380	160
Without Hole / Without Handle	AHLNA	100	39	16	30	15	5	16	48.5	55	37	12	12	4	1.8	12	*10	12	10	9	9.5	5.5	5	5	600	250
H8 Hole + Tapped	AHLNK	125	40	17	33	28	6	16	48.5	55	46.5	12	12	4	1.8	12	*12	13	8	—	—	—	6	6	900	345
H8 Hole + Keyway + Tapped	AHLNM	140	44	18	35	30	6	20	62.5	70.7	53.5	15	15	5	2.3	14	*15	—	—	—	—	—	—	—	1100	425
Slit	AHLNF	200	59.5	24	43	41	10	25	77.5	87.3	81	16	16	5	2.3	16	16	15	10.5	12.5	6.5	6	10	—	1400	560
Square Hole	AHLNW	250	65	27	48	44	10	25	77.5	87.3	100	20	20	5	2.3	17	20	—	—	—	—	—	—	—	2800	1140
Slit	AHLND	250	65	27	48	44	10	25	77.5	87.3	100	20	20	5	2.3	17	20	—	—	—	—	—	—	—	4900	—

*marked items are applicable for With Slit AHLNF only.
 Diameter 250 is not available for AHLNA, AHLNAK, AHLND, AHLNF, AHLN-R.

Part Number Example
 Part Number: AHLN160
 d: 10

Part Number Alterations
 Part Number: AHLNAK200
 Alterations: - (HC / KC / SC) SC20

Shaft bore (H8) and square bore dimensions are configurable.
 Only applicable to types with no Holes.

Alterations	H8 Hole (Dimension Configurable) + Tapped Hole Machining	H8 Hole (Dimension Configurable) + Keyway + Tapped Hole Machining	Square Boring (Dimensions Configurable)																																																																																																													
Code	HC	KC	SC																																																																																																													
Spec.	Adds an H8 hole at hub center, and two tapped setscrew holes. HC=1 mm Increment Ordering Code: HC16 <table border="1"> <tr><th>D</th><th>HC(H8)</th><th>h</th><th>HC(H8)</th><th>M (Coarse)</th></tr> <tr><td>80</td><td>10-15</td><td>6</td><td>10-16</td><td>5</td></tr> <tr><td>100</td><td>10-16</td><td>6</td><td>17-19</td><td>6</td></tr> <tr><td>125</td><td>12-18</td><td>8</td><td>20-23</td><td>8</td></tr> <tr><td>140</td><td>14-19</td><td>8</td><td>—</td><td>—</td></tr> <tr><td>160</td><td>14-20</td><td>8</td><td>—</td><td>—</td></tr> <tr><td>200 / 250</td><td>16-23</td><td>10</td><td>—</td><td>—</td></tr> </table>	D	HC(H8)	h	HC(H8)	M (Coarse)	80	10-15	6	10-16	5	100	10-16	6	17-19	6	125	12-18	8	20-23	8	140	14-19	8	—	—	160	14-20	8	—	—	200 / 250	16-23	10	—	—	Adds an H8 Hole at hub center, a key groove and its tapped hole. KC=Selectable Ordering Code: KC15 <table border="1"> <tr><th>D</th><th>KC(H8)</th><th>M</th><th>h</th><th>KC(H8)</th><th>b</th><th>t</th></tr> <tr><td>80</td><td>10 11 12</td><td>6</td><td>6</td><td>10</td><td>3</td><td>±0.0125 1.4</td></tr> <tr><td>100</td><td>—</td><td>—</td><td>—</td><td>11 / 12</td><td>4</td><td>1.8</td></tr> <tr><td>125</td><td>12 14</td><td>5</td><td>8</td><td>14-17</td><td>5</td><td>±0.0150 2.3</td></tr> <tr><td>140</td><td>14 15 16</td><td>8</td><td>—</td><td>—</td><td>—</td><td>—</td></tr> <tr><td>160</td><td>—</td><td>—</td><td>—</td><td>—</td><td>—</td><td>—</td></tr> <tr><td>200 / 250</td><td>16 17 18</td><td>6 10</td><td>10</td><td>18</td><td>6</td><td>2.8</td></tr> </table>	D	KC(H8)	M	h	KC(H8)	b	t	80	10 11 12	6	6	10	3	±0.0125 1.4	100	—	—	—	11 / 12	4	1.8	125	12 14	5	8	14-17	5	±0.0150 2.3	140	14 15 16	8	—	—	—	—	160	—	—	—	—	—	—	200 / 250	16 17 18	6 10	10	18	6	2.8	Adds a square hole at hub center. SC=1mm Increment Ordering Code: SC12 <table border="1"> <tr><th>D</th><th>SC</th><th>SC</th><th>Tolerance</th><th>C</th></tr> <tr><td>80 / 100</td><td>10-12</td><td>10-14</td><td>+0.1 0</td><td>0.5</td></tr> <tr><td>125</td><td>10-14</td><td>—</td><td>—</td><td>—</td></tr> <tr><td>140 / 160</td><td>10-17</td><td>15-20</td><td>+0.15 0</td><td>1</td></tr> <tr><td>200 / 250</td><td>10-20</td><td>—</td><td>—</td><td>—</td></tr> </table>	D	SC	SC	Tolerance	C	80 / 100	10-12	10-14	+0.1 0	0.5	125	10-14	—	—	—	140 / 160	10-17	15-20	+0.15 0	1	200 / 250	10-20	—	—	—
D	HC(H8)	h	HC(H8)	M (Coarse)																																																																																																												
80	10-15	6	10-16	5																																																																																																												
100	10-16	6	17-19	6																																																																																																												
125	12-18	8	20-23	8																																																																																																												
140	14-19	8	—	—																																																																																																												
160	14-20	8	—	—																																																																																																												
200 / 250	16-23	10	—	—																																																																																																												
D	KC(H8)	M	h	KC(H8)	b	t																																																																																																										
80	10 11 12	6	6	10	3	±0.0125 1.4																																																																																																										
100	—	—	—	11 / 12	4	1.8																																																																																																										
125	12 14	5	8	14-17	5	±0.0150 2.3																																																																																																										
140	14 15 16	8	—	—	—	—																																																																																																										
160	—	—	—	—	—	—																																																																																																										
200 / 250	16 17 18	6 10	10	18	6	2.8																																																																																																										
D	SC	SC	Tolerance	C																																																																																																												
80 / 100	10-12	10-14	+0.1 0	0.5																																																																																																												
125	10-14	—	—	—																																																																																																												
140 / 160	10-17	15-20	+0.15 0	1																																																																																																												
200 / 250	10-20	—	—	—																																																																																																												

Two-Spoked Handwheels

Two-Spoked Handwheels	Type			Handwheel		Handle		Handle Thread	
	Without Handle	Stationary Handles	Revolving Handles	Material	Surface Treatment	Material	Surface Treatment	Material	Surface Treatment
SHLNN	—	—	SHLN	SCS22 Stainless Cast (JIS) Stainless Cast (JIS)	Shot Blasted	304 Stainless Steel	Electrolytic Polishing	304 Stainless Steel	Electrolytic Polishing
	—	AHTN	AHTNK	Cast Iron Class No.30	Chrome Plating	1018 Carbon Steel or Equivalent	Chrome Plating	1018 Carbon Steel	Chrome Plating
—	—	—	AHTNAK	Aluminum Casting Alloy 333.0	Shot Blasted+ Buffed Surface	2024 Aluminum Alloy	Shot Blasted	1018 Carbon Steel	Chrome Plating
—	—	—	AHTNA	—	—	—	—	—	—

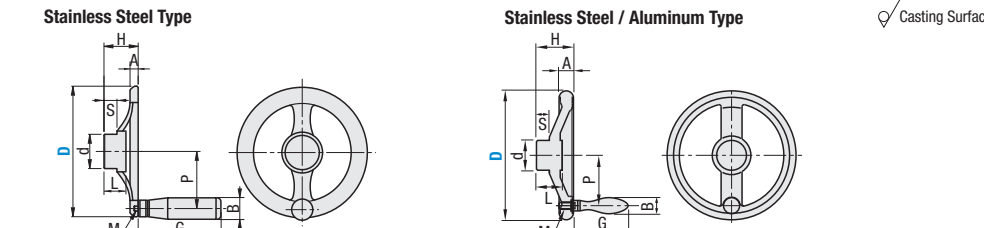

RoHS 10
 Stainless Steel Handles are GRMS on P.3201, and Steel Handles are GRMK on P.3201. In addition, Aluminum Handles are GRMAK on P.3201

Stainless Steel SHLNN / SHLN

Part Number	Type	D	H	A	S	d	L	M	B	G	P	Reference Mass (g)	
												With Handle	Without Handle
Without Handle	SHLNN	80	22	6.5	7	20	11.7	5	10	45	35.6	425	400
Revolving Handles	SHLN	100	27	7.5	8.7	25	14.6	6	13	57	43.5	605	550
		125	32	8	10.9	31	18.3	6	13	57	54.7	755	700
		140	36	9	12.2	35	20.5	8	16	68	62.5	935	880
Revolving Handles	SHLN	160	40	9	14	40	23.4	8	16	68	71.5	1300	1200
		200	50	11.3	17.4	50	32	10	20	80	90	2180	2000

Steel AHTN / AHTNK Aluminum AHTNA / AHTNAK

Part Number	Type	D	H	A	S	d	L	M		B	G		P	Reference Mass (g)	
								Steel	Aluminum		Standard	Rotating		Steel	Aluminum
Steel Stationary Handles	AHTN	80	36	14	—	24	24	5	—	13	38.5	49	28	370	138
Steel Revolving Handles	AHTNK	100	39	15	15	30	28	5	—	13	38.5	49	37	575	215
Aluminum Stationary Handles	AHTNA	125	40	16	—	33	—	6	8	16	48.5	55	46.5	895	310
Aluminum Revolving Handles	AHTNAK	140	44	17	16	35	30	6	—	16	48.5	55	52.5	1095	380
Aluminum Revolving Handles	AHTNAK	160	46	18	—	37	32	8	—	20	62.5	70.7	62.5	1460	485
Aluminum Revolving Handles	AHTNAK	200	59.5	24	19	43	41	10	10	25	77.5	87.3	81	2890	890

Part Number Example
 Part Number: AHTN80
 Alterations: SHLN100, AHTNAK200

Part Number Alterations
 Part Number: AHTN80
 Alterations: - (HC / KC / SC) HC10, KC11, SC20

Alterations	H8 Hole (Dimension Configurable) + Tapped Hole Machining	H8 Hole (Dimension Configurable) + Keyway + Tapped Hole Machining	Square Boring (Dimensions Configurable)																																																																																																													
Code	HC	KC	SC																																																																																																													
Spec.	Adds an H8 hole at hub center, and two tapped setscrew holes. HC=1 mm Increment Ordering Code: HC16 <table border="1"> <tr><th>D</th><th>HC(H8)</th><th>h</th><th>HC(H8)</th><th>M (Coarse)</th></tr> <tr><td>80</td><td>10-15</td><td>6</td><td>10-16</td><td>5</td></tr> <tr><td>100</td><td>10-16</td><td>6</td><td>17-19</td><td>6</td></tr> <tr><td>125</td><td>12-18</td><td>8</td><td>20-23</td><td>8</td></tr> <tr><td>140</td><td>14-19</td><td>8</td><td>—</td><td>—</td></tr> <tr><td>160</td><td>14-20</td><td>8</td><td>—</td><td>—</td></tr> <tr><td>200 / 250</td><td>16-23</td><td>10</td><td>—</td><td>—</td></tr> </table>	D	HC(H8)	h	HC(H8)	M (Coarse)	80	10-15	6	10-16	5	100	10-16	6	17-19	6	125	12-18	8	20-23	8	140	14-19	8	—	—	160	14-20	8	—	—	200 / 250	16-23	10	—	—	Adds an H8 Hole at hub center, a key groove and its tapped hole. KC=Selectable Ordering Code: KC15 <table border="1"> <tr><th>D</th><th>KC(H8)</th><th>M</th><th>h</th><th>KC(H8)</th><th>b</th><th>t</th></tr> <tr><td>80</td><td>10 11 12</td><td>6</td><td>6</td><td>10</td><td>3</td><td>±0.0125 1.4</td></tr> <tr><td>100</td><td>—</td><td>—</td><td>—</td><td>11 / 12</td><td>4</td><td>1.8</td></tr> <tr><td>125</td><td>12 14</td><td>5</td><td>8</td><td>14-17</td><td>5</td><td>±0.0150 2.3</td></tr> <tr><td>140</td><td>14 15 16</td><td>8</td><td>—</td><td>—</td><td>—</td><td>—</td></tr> <tr><td>160</td><td>—</td><td>—</td><td>—</td><td>—</td><td>—</td><td>—</td></tr> <tr><td>200 / 250</td><td>16 17 18</td><td>6 10</td><td>10</td><td>18</td><td>6</td><td>2.8</td></tr> </table>	D	KC(H8)	M	h	KC(H8)	b	t	80	10 11 12	6	6	10	3	±0.0125 1.4	100	—	—	—	11 / 12	4	1.8	125	12 14	5	8	14-17	5	±0.0150 2.3	140	14 15 16	8	—	—	—	—	160	—	—	—	—	—	—	200 / 250	16 17 18	6 10	10	18	6	2.8	Adds a square hole at hub center. SC=1mm Increment Ordering Code: SC12 <table border="1"> <tr><th>D</th><th>SC</th><th>SC</th><th>Tolerance</th><th>C</th></tr> <tr><td>80 / 100</td><td>10-12</td><td>10-14</td><td>+0.1 0</td><td>0.5</td></tr> <tr><td>125</td><td>10-14</td><td>—</td><td>—</td><td>—</td></tr> <tr><td>140 / 160</td><td>10-17</td><td>15-20</td><td>+0.15 0</td><td>1</td></tr> <tr><td>200 / 250</td><td>10-20</td><td>—</td><td>—</td><td>—</td></tr> </table>	D	SC	SC	Tolerance	C	80 / 100	10-12	10-14	+0.1 0	0.5	125	10-14	—	—	—	140 / 160	10-17	15-20	+0.15 0	1	200 / 250	10-20	—	—	—
D	HC(H8)	h	HC(H8)	M (Coarse)																																																																																																												
80	10-15	6	10-16	5																																																																																																												
100	10-16	6	17-19	6																																																																																																												
125	12-18	8	20-23	8																																																																																																												
140	14-19	8	—	—																																																																																																												
160	14-20	8	—	—																																																																																																												
200 / 250	16-23	10	—	—																																																																																																												
D	KC(H8)	M	h	KC(H8)	b	t																																																																																																										
80	10 11 12	6	6	10	3	±0.0125 1.4																																																																																																										
100	—	—	—	11 / 12	4	1.8																																																																																																										
125	12 14	5	8	14-17	5	±0.0150 2.3																																																																																																										
140	14 15 16	8	—	—	—	—																																																																																																										
160	—	—	—	—	—	—																																																																																																										
200 / 250	16 17 18	6 10	10	18	6	2.8																																																																																																										
D	SC	SC	Tolerance	C																																																																																																												
80 / 100	10-12	10-14	+0.1 0	0.5																																																																																																												
125	10-14	—	—	—																																																																																																												
140 / 160	10-17	15-20	+0.15 0	1																																																																																																												
200 / 250	10-20	—	—	—																																																																																																												