

Gas Springs

Gas Springs



FGS

No.15049~No.18200

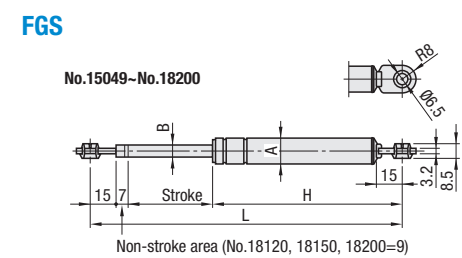

No.22250~No.22360

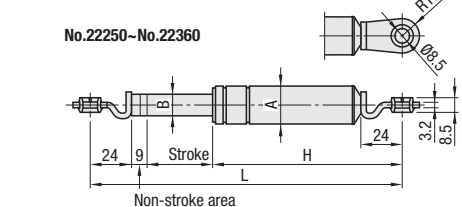

Operating Temperature: -20~60°C
For No.15049, operating temperature should be 0~60°C.

Material:
Cylinder: 1008 Pipe Steel (Carbon Steel Hollows for Machine Structural Use)
Rod: 1020 Carbon Steel
Bushing: Polyacetal Resin (White)
Gas: Nitrogen Gas (N₂)
Surface Treatment: Cylinder: Baked-On (Black Matt)
Rod: Hard Chrome Plating

Type	Part Number	Max. Length (Lmax)	Min. Length (Lmin)	Stroke	Gas Reaction Force (20°C)				Outer Dia.	Rod Dia.	H	Applicable Mounting Brackets	Weight (g)										
					Lmax - 10 mm Stroke		Lmax - (S) In the Stroke																
					N	kgf	N	kgf						(S)									
FGS	15049 - 030	181	132	49	30	3.0	40	4.1	15	7	110	GSBR6A GSBR6B GSBR6C GSBR6D P2561	83										
	15049 - 055				55	6.0	71	7.2						39									
	15049 - 085				85	9.0	109	11.1															
	15049 - 150				150	15.0	191	19.5															
	15069 - 050				50	5.0	67	6.8							59								
	15069 - 080				80	8.0	107	10.9															
	15069 - 120				120	12.0	158	16.1															
	15089 - 070				70	7.0	94	9.6								79							
	15089 - 100				100	10.0	135	13.8															
	15089 - 150				150	15.0	202	20.6															
	15089 - 200				200	20.0	268	27.3															
	15099 - 075				75	8.0	101	10.3									89						
	15099 - 120				120	12.0	162	16.5															
	15099 - 200				200	20.0	270	27.6															
	18120 - 100				100	10.0	123	13.0										110					
	18120 - 200				200	20.0	245	25.0															
	18120 - 300				300	31.0	367	37.0															
	18120 - 400				400	41.0	489	50.0															
	18150 - 100				100	10.0	126	12.9											140				
	18150 - 150				150	15.0	188	19.2															
	18150 - 200				200	20.0	251	25.6															
	18150 - 250				250	26.0	313	31.9															
	18200 - 100				100	10.0	127	13.0												190			
	18200 - 150				150	15.0	190	19.4															
	18200 - 200				200	20.0	253	25.8															
	18200 - 300				300	31.0	379	38.7															
	22250 - 100				100	10.0	129	13.2													240		
	22250 - 200				200	20.0	257	26.2															
	22250 - 300				300	31.0	384	39.2															
	22250 - 400				400	41.0	511	52.1															
	22270 - 345				345	35.0	528	53.9														260	
	22270 - 500				500	51.0	763	77.9															
	22270 - 700				700	71.0	1065	108.7															
	22290 - 745				745	76.0	1160	118.4															280
	22290 - 845				845	86.0	1314	134.1															
	22300 - 200				200	20.0	257	26.2															
22300 - 250	250	26.0	321	32.8																			
22300 - 300	300	31.0	385	39.3																			
22360 - 215	215	22.0	284	29.0	350																		
22360 - 345	345	35.0	456	46.5																			

Part Number Example	Part Number	-	Reaction
	FGS15049	-	150

Gas Springs

Limited Mounting Orientation

Gas Springs (Attaching Bracket) - Limited Mounting Orientation



RoHS 10

GSS

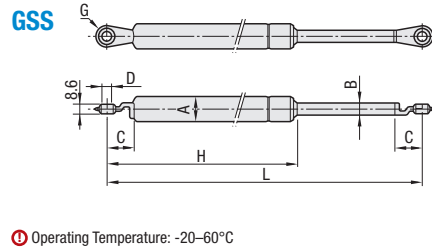

Twisted Angle ±5° or less

Material:
Cylinders: STKM12BEC(JIS) (Carbon Steel Hollows for Machine Structural Use)
Rod: 1035 Carbon Steel
Bushings: Polyacetal Resin (White)
Gas: Nitrogen Gas (N₂)
Surface Treatment:
Cylinders: Baking Finish (Black Matte)
Rod: Gas Soft Nitriding Treatment

Operating Temperature: -20~60°C

Gas Springs

Type	Part Number	Max. Length (Lmax)	Min. Length (Lmin)	Stroke	Gas Reaction Force (20°C)					A	B	C ₁	C ₂	D	G	H	Applicable Mounting Brackets	Weight (g)														
					Max. Length 10 mm		Max. Length () mm		(S)																							
					N	kgf	N	kgf																								
GSS	15050A	181.0	131.0	50.0	27	2.8	32	3.4	40	15	6	15	15	6.5	R8	110	GSSB6A	75														
	15050B				85	8.7	102	10.4																								
	15050C				147	15.0	175	17.9																								
	15050D				186	19.0	222	22.7																								
	15050E				206	21.0	245	25.0																								
	15070A				81	8.3	102	10.4											60													
	15070B				119	12.1	124	12.7																								
	15070C				196	20.0	245	25.0																								
	15090A				69	7.0	89	9.1												80												
	15090B				79	8.1	103	10.5																								
	15090C				88	9.0	115	11.7																								
	15090D				147	15.0	191	19.5																								
	15090E				196	20.0	254	25.9																								
	15100A				76	7.8	103	10.5													90											
	15100K				110	11.2	147	15.0																								
	15100B				196	20.0	257	26.2																								
	18090A				263	26.8	343	35.0														80										
	18100A				324	33.1	428	43.7																								
	22080K				116	11.8	142	14.5															70									
	22080A				196	20.0	237	24.2																								
	22080B				246	25.1	299	30.5																								
	22096A				392	40.0	494	50.4																86								
	22142A				279	28.5	372	38.0																								
	22147A				147	15.0	194	19.8																	130							
	22147B				240	24.5	314	32.0																								
	22150A				343	35.0	408	41.6																		140						
	22210A				587	59.9	799	81.5																								
	22210B				667	68.1	908	92.7																								
	22235A				129	13.2	195	19.9																			206					
	22235B				248	25.3	314	32.0																								
	22235C				343	35.0	435	44.4																								
	22235D				507	51.7	642	65.5																								
	22243A				196	20.0	301	30.7																				215				
	22243B				433	44.2	657	67.0																								
	22253A				311	31.7	367	37.4																					197			
	22270K				127	13.0	190	19.4																								
	22270A				343	35.0	497	50.7																						240		
	22270L				406	41.4	588	60.0																								
	22270B				507	51.7	739	75.4																								
	22270C				596	60.8	868	88.6																								
	22270D				755	77.0	1104	112.7																								
	22300K				596	60.8	966	98.6																							290	
	22300A				745	76.0	1160	118.4																								
	22300B				850	86.7	1320	134.7																								
	22315A				833	85.0	1220	124.5																								305
	22356A				216	22.0	288	29.4																								
	22356B				345	35.2	460	46.9																								

Part Number Example	Part Number
	GSS15050B