





Toggle Clamps

Hold Down, Vertical Handle, Long Arm (Straight Base)

 <p>Clamp Condition</p>	Part Number	MC04-1LS	 <p>Clamp Condition</p>	Part Number	MC04-2LS
	Body Material	1018 Carbon Steel or Equivalent		Body Material	1018 Carbon Steel or Equivalent
	Surface Treatment	Trivalent Chromate		Surface Treatment	Trivalent Chromate
	Tightening Force (N)	186		Tightening Force (N)	392
	Weight (g)	75		Weight (g)	175
	Open-Close Angle of Arm	104°		Open-Close Angle of Arm	98°
	Open-Close Angle of Handle	62°		Open-Close Angle of Handle	62°
Accessories	Bolt with Rubber Material: NBR Nitrile Rubber Hardness: Shore A70		Accessories	Bolt with Rubber Material: NBR Nitrile Rubber Hardness: Shore A70	

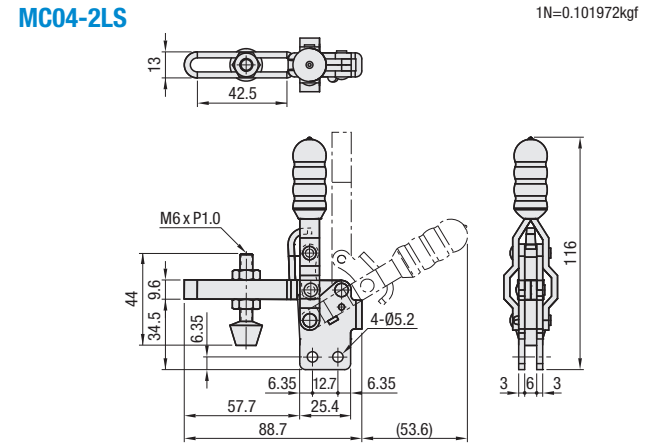
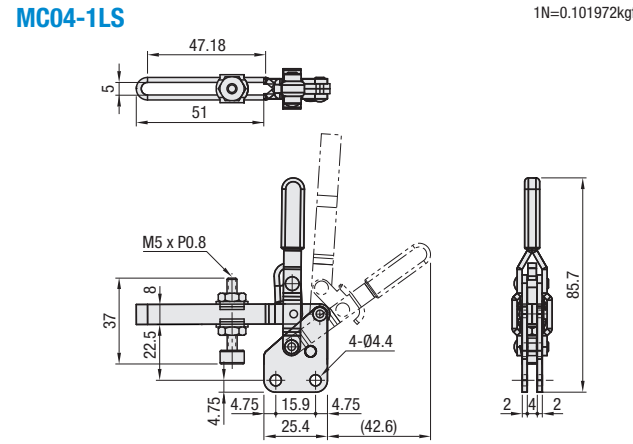

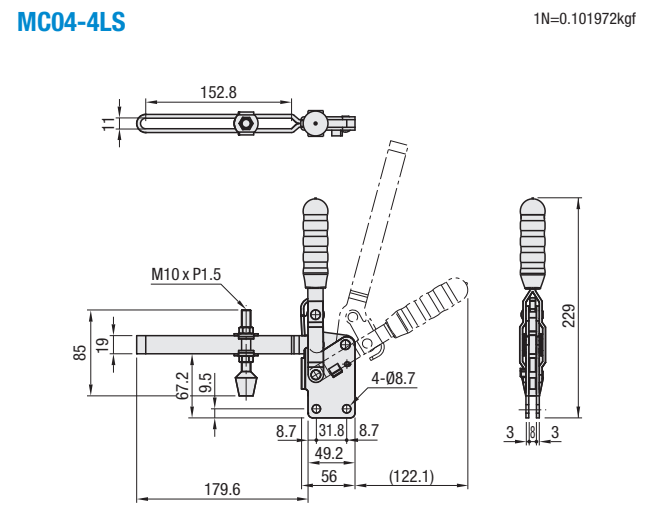
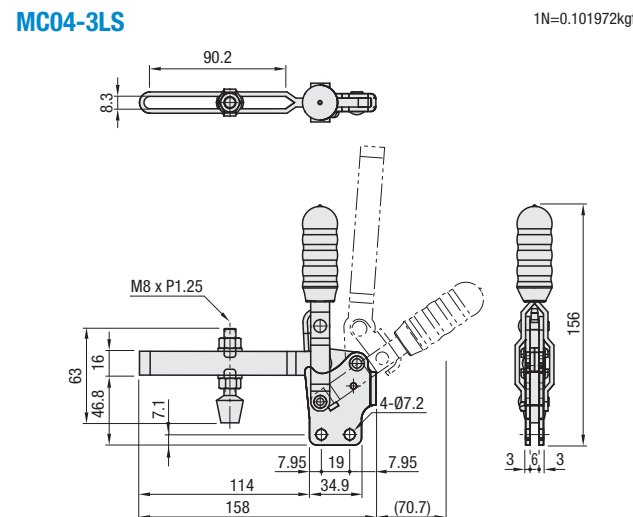

 <p>Clamp Condition</p>	Part Number	MC04-3LS	 <p>Clamp Condition</p>	Part Number	MC04-4LS
	Body Material	1018 Carbon Steel or Equivalent		Body Material	1018 Carbon Steel or Equivalent
	Surface Treatment	Trivalent Chromate		Surface Treatment	Trivalent Chromate
	Tightening Force (N)	784		Tightening Force (N)	1078
	Weight (g)	370		Weight (g)	815
	Open-Close Angle of Arm	105°		Open-Close Angle of Arm	118°
	Open-Close Angle of Handle	59°		Open-Close Angle of Handle	73°
Accessories	Bolt with Rubber Material: NBR Nitrile Rubber Hardness: Shore A70		Accessories	Bolt with Rubber Material: NBR Nitrile Rubber Hardness: Shore A70	





Part Number Example **MC04-3LS**

Toggle Clamps

Hold Down, Vertical Handle (Flange Base)

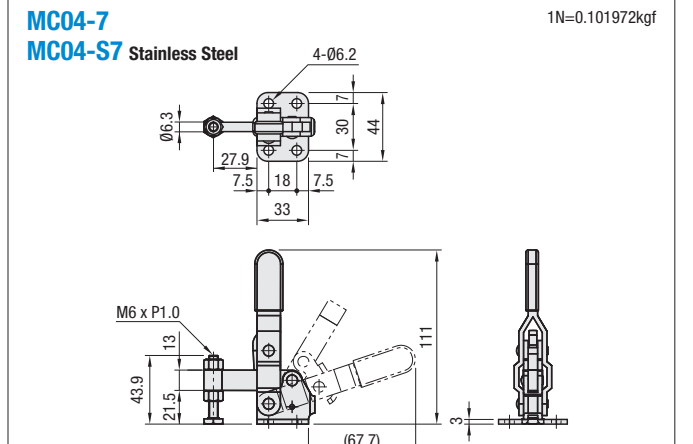
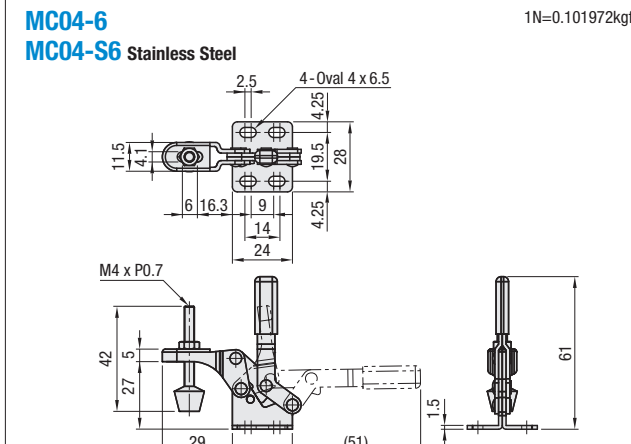
 <p>Clamp Condition</p>	Part Number	MC04-6	MC04-S6	 <p>Clamp Condition</p>	Part Number	MC04-7	MC04-S7
	Body Material	1018 Carbon Steel or Equivalent	304 Stainless Steel		Body Material	1018 Carbon Steel or Equivalent	304 Stainless Steel
	Surface Treatment	Trivalent Chromate	—		Surface Treatment	Trivalent Chromate	—
	Tightening Force (N)	294	—		Tightening Force (N)	980	—
	Weight (g)	40	—		Weight (g)	200	—
	Open-Close Angle of Arm	85°	—		Open-Close Angle of Arm	105°	—
	Open-Close Angle of Handle	90°	—		Open-Close Angle of Handle	67°	—
Accessories	Bolt with Rubber Material: NBR Nitrile Rubber Hardness: Shore A70		Stainless Steel Bolt with Rubber	Accessories	Steel Bolt	Stainless Steel Bolt	

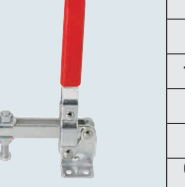

 <p>Clamp Condition</p>	Part Number	MC04-8	MC04-S8	 <p>Clamp Condition</p>	Part Number	MC04-9
	Body Material	1018 Carbon Steel or Equivalent	304 Stainless Steel		Body Material	1018 Carbon Steel or Equivalent
	Surface Treatment	Trivalent Chromate	—		Surface Treatment	Trivalent Chromate
	Tightening Force (N)	1470	—		Tightening Force (N)	1960
	Weight (g)	370	—		Weight (g)	420
	Open-Close Angle of Arm	98°	—		Open-Close Angle of Arm	108°
	Open-Close Angle of Handle	56°	—		Open-Close Angle of Handle	71°
Accessories	Steel Bolt	Stainless Steel Bolt	Accessories	Steel Bolt		

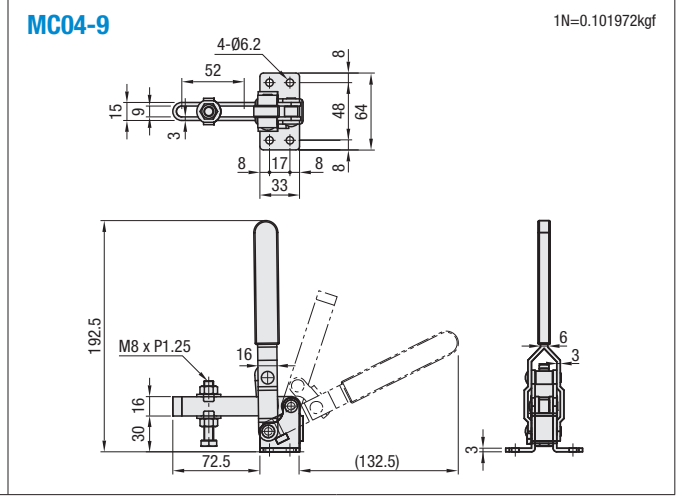
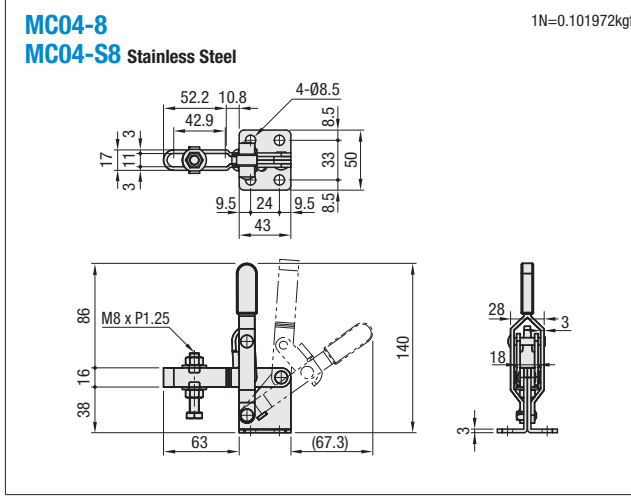

Part Number Example **MC04-6**

