

MOTORIZED STAGES Z-AXIS LINEAR BALL CAVE-X POSITIONER

[High Precision] Motorized Z-Axis - Linear Ball, CAVE-X POSITIONER

Compact



For CAD data, see the MISUMI website.

Features: Z-Axis Type with High Rigidity, Compactness in width and the Space-saving design for the overall length.

Z-Axis, Compact

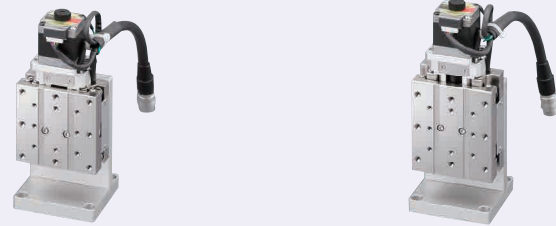

M Material: 440C Stainless Steel
S Surface Treatment: Electroless Nickel Plating
A Accessory: SCB4-12 (4 pcs.)



For Controllers, Handset Terminals, see P.1-1735-93-P.1-1735-94

ZCV620-C

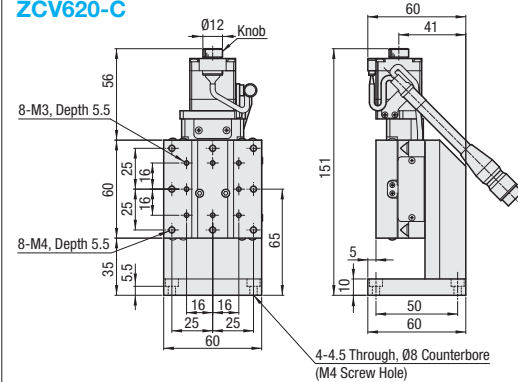

ZCV630-C

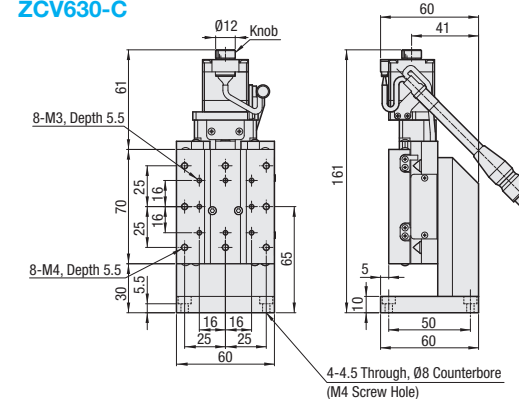

ZCV620-F

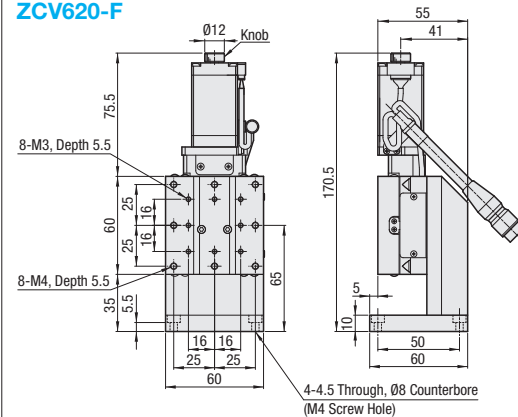

ZCV630-F

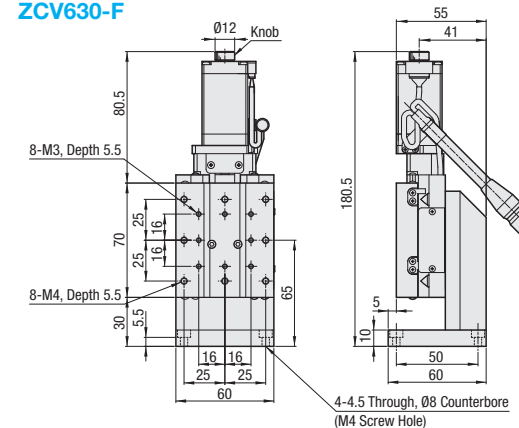

ZCV620-G

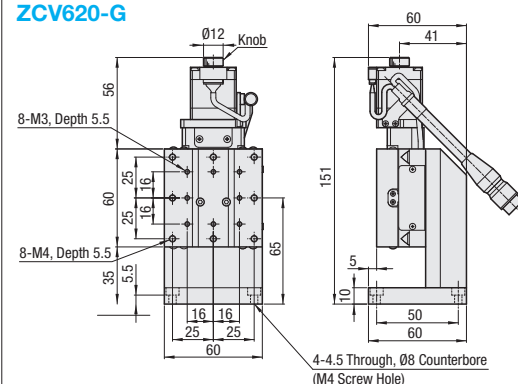

ZCV630-G

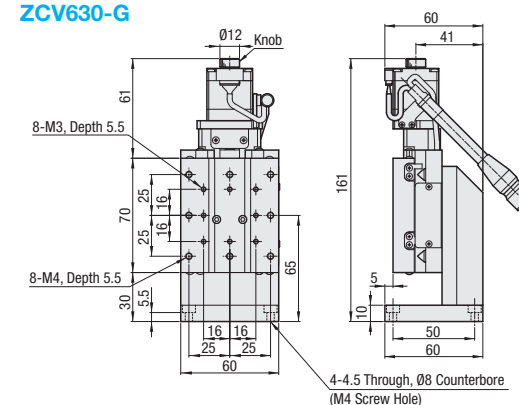

For the detailed dimensions of CAVE-X Positioner with the Motor PA installed, see the applicable CAD data.

Part Number	Type	No.	Motor	Cable	Mechanical Standards			Accuracy Standards		
					Stage Surface (mm)	Travel Distance (mm)	Weight ² (kg)	Unidirectional Positioning Accuracy (for a single axis stage horizontally placed)	Pitching	Yawing
ZCV		620	C (Standard) F (High Torque) G (High Resolution)	N (Cable not included (separately sold)) M (For Motor with Electromagnetic Brake) P (For α-Step)	60×60	20	1.1	5μm	20"	15"
		630	MA ¹ (With Electromagnetic Brake) PA ¹ (α-Step)	For combination of motors and cables, see the table below.	60×70	30	1.3			

*1. For motor options MA and PA, the driver is included in the set. With motor options MA and PA, the selectable cable options are M and P, respectively and exclusively. Note that the cable option N is not selectable.
 *2. The value is for C Type of Motor.



Ordering Example: Part Number - Motor - Cable
 ZCV620 - C - N
 ZCV630 - PA - P



Days to Ship

Configure Online

Motor/Cable Application Table

Motor	Cable
C, F, G	N (Not Provided)
MA	M
PA	P

For information on cables for motor options C, F and G, see MSCB on P.1-1735-95

Max. Speed

Motor	(mm/sec)
C	30
F	35
G	25
MA	25
PA	40

Note that the speed and positioning time differ depending on the current condition of use. The speed and positioning time are not guaranteed values but reference values provided by MISUMI.

Common Specifications

Feed Screw	Ball Screw Ø8, Lead 1	
Guide	Linear Ball Guide	
Resolution ³	Full	2μm/Pulse (1μm/Pulse) ⁴
	Half	1μm/Pulse (0.5μm/Pulse) ⁴
	Fine Feed (upon 1/20 partitioned)	0.1μm (0.05μm)
Max. Speed ⁵	20mm/sec (30mm/sec) ⁶ (Pulse Rate: 5kHz)	
Positioning repeatability	±0.5μm	
Load Capacity ⁷	29.4N	
Lost Motion	1μm	
Backlash	1μm	
Straightness	3μm	
Parallelism	15μm	
Motion Parallelism	10μm	

*3 The above specifications table is for a single axis stage placed flatly.

*4 The values in () are for Motor Option G (High Resolution).

*5 This represents the max. speed that can be driven by the recommended controller switched to Full Step mode, with the max. load applied. (The value differs depending on the current driving controller and the current load.)

*6 The values in () are for Motor Option F (High Torque).

*7 The above load capacity value is for Z-Axis.

Connector Pin Configuration

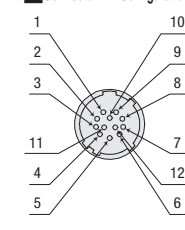

Wiring Diagram

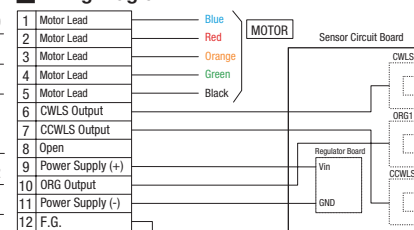

Electrical Specifications

Motor	Type	C	F	G	MA	PA
		Standard	High Torque	High Resolution	With Electromagnetic Brake	Tuningless
5-Phase Stepping Motor 0.75A/Phase (Oriental Motor Co., Ltd.)						
Step Angle		0.72°	0.72°	0.36°	0.72°	0.36° (When 1000P/R is set)
Connector		Applicable Receptacle Connector: HR10A-10P-12S(73)(Hirose Electric Co., LTD.)			5559-06R-210 (Molex Japan LLC)	43020-1000 (Molex Japan LLC)
Limit Sensor		Provided				
Home Sensor		Photomicrosensor: EE-SX4320 (OMRON Corp.)				
Near Home Sensor						
Power Supply Voltage		DC5-24V ±10%				
Current Consumption		60mA or less in Total				
Control Output		NPN Open Collector Output DC5-24V, 8mA or less Residual Voltage 0.3V or less (when load current is 2mA)				
Output Logic		Detecting (Dark): Output Transistor OFF (Non-Conducting)				

Sensors with Part Number EE-SX4134 will be discontinued and replaced by next-generation products with Part Number EE-SX4320 from November 2018.

Timing Chart

ZCV620

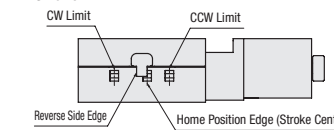

ZCV630

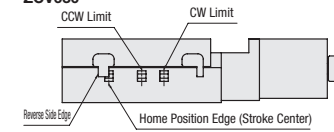

(Unit: mm)

Reference Position	Mechanical Limit	CW Limit	Home Position Edge Stroke Center	Other Signal Edge	CCW Limit	Mechanical Limit
ZCV620 Homing	11	10.5	0	5	10.5	13
ZCV630 Homing	16	15.5	0	5	15.5	18

Homing mentioned here means that Homing Routine Type 4 is executed by using the MSCTL102 Series controller.

The coordinates shown are design values. There may be approx. ±0.5mm misalignment on the physical dimensions.

For details about Homing, see P.1-1735-97

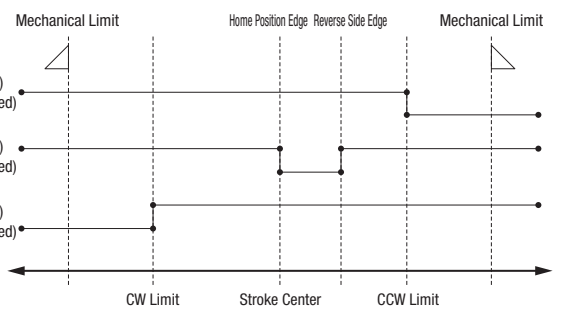

Recommended Homing Method

Type3	After detection is executed in the CW direction, the process of detecting in the CW direction is begun based on the ORG signal.
Type4	After detection is executed in the CW direction, the process of detecting in the CW direction is begun based on the ORG signal.
Type9	After Type 3 is executed, the process of detecting in the CCW direction is begun based on the TIMING signal.
Type10	After Type 4 is executed, the process of detecting in the CW direction is begun based on the TIMING signal.