

# MechaLock - Keyless Bushings

## Overview

### Features of MechaLock Keyless Bushings

- The MechaLock is a fastening tool to tightly fasten a hub to a shaft by using friction. This is accomplished by converting screw tightening power into pressure on the tapered inner diameter surface of the hub and the tapered O.D. of the shaft.
- A hub (such as pulleys, gears and sprockets) can be easily connected with a shaft by screwing.
- It is well suitable for applications with repeated forward / backward rotation as it virtually eliminates backlash.
- It can also handle some thrust.
- Design allows for infinite phase adjustment after installation.
- It saves complex key machining on shafts and hubs as well as polishing in assembling, which leads to total cost reduction.

### Structure of MechaLock Keyless Bushings

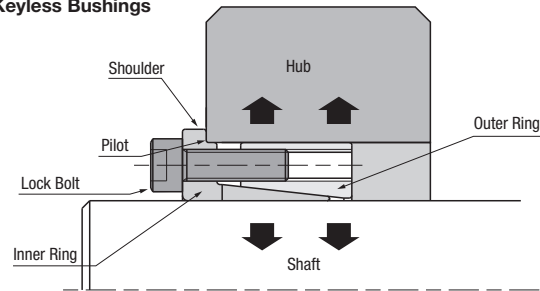

### Installation

- Wipe off the shaft surface and apply oil or grease. (Do not use any oil or grease containing molybdenum disulfide agent.)
- Wipe off and apply oil and grease on contact surfaces of MechaLock and Hub. Apply oil or grease to the thread and seat of lock screws.
- Please insert the shaft after assembling the MechaLock and Hubs temporarily. (Do not tighten the screws before inserting the shaft)
- After locating, tighten the locking screws using a torque wrench in the diagonal line order, beginning lightly (approx. 1/4 of the predetermined tightening torque).
- Tighten the screws further to an increased torque (approximately 1/2 of specified torque).
- Tighten the screws up to the specified torque.
- Finally tighten the locking screws in circumferential order.

### Cautions

- Be sure to apply oil or grease to shaft surfaces, contact surfaces b/w MechaLocks and hubs, tightening screws before installation. If not, the MechaLock may not be tightened firmly; the shaft may slip at rotation. However, do not use oil or grease with tapered portion of inner and outer ring.
- Tapered portion of inner ring and outer ring will get into each other even with a little shock from conveyance. Loosen the screw and nut and disassemble parts to release tapered parts before installation.
- Please insert the shaft after assembling the MechaLock and Hubs temporarily. (Please do not tighten the screw before inserting the shaft. MechaLock may deform.)
- Use a torque wrench to tighten the screws.
- Do not use lock screws other than those included.

### Removal

- Be sure to work after the system is completely shut down.
- Loosen the lock screws in circumferential order.
- Insert a screw in a hole for removal and tighten evenly.
- Repeat "Installation" process for re-installation.

### Selection Table

Part Number	MLSL	MLR, MLRP, MLRS	MLM, MLMB, MLMMP, MLHS	MLA, MLAP, MLAT	MLN, MLNB, MLNP
Page	P.1240	P.1241	P.1243	P.1245, 1246	P.1246
Series	Thin	Compact	Standard	Straight Straight for High Torque	Nut
Allowable Torque	△	○	○	○	○
Thin (I.D./O.D. Difference)	○	○	○	○	○
Lightness	○	○	○	○	○
Centering Function	×	○	○	×	×
Installation	△	○	○	○	○
Price	○	○	○	○	○
Feature	Because the screw is installed directly on the hub, the inner and outer diameter difference is small and thin. Applicable to installation on a small hub. Suitable for the aluminum belt pulley, etc.	Because mounting tap of the screw is built in the flange, the inner and outer diameter difference is small and thin. Applicable to installation on a small hub. Centering function is equipped.	Most widely used locking mechanism. High-performance centering function. Available in wide range of sizes, materials and types of surface treatment.	Has larger maximum allowable torque than Standard Type, and locks the shaft and hub firmly. Compact Straight Type for high torque is also available.	Installation can be completed by tightening one nut and is much easier than the conventional locking screw type.

① Can be used on shafts with keyways with width within JIS standards but allowable torque and thrust ratings will be reduced by 15~20%.

# MechaLock - Keyless Bushings

## Thin

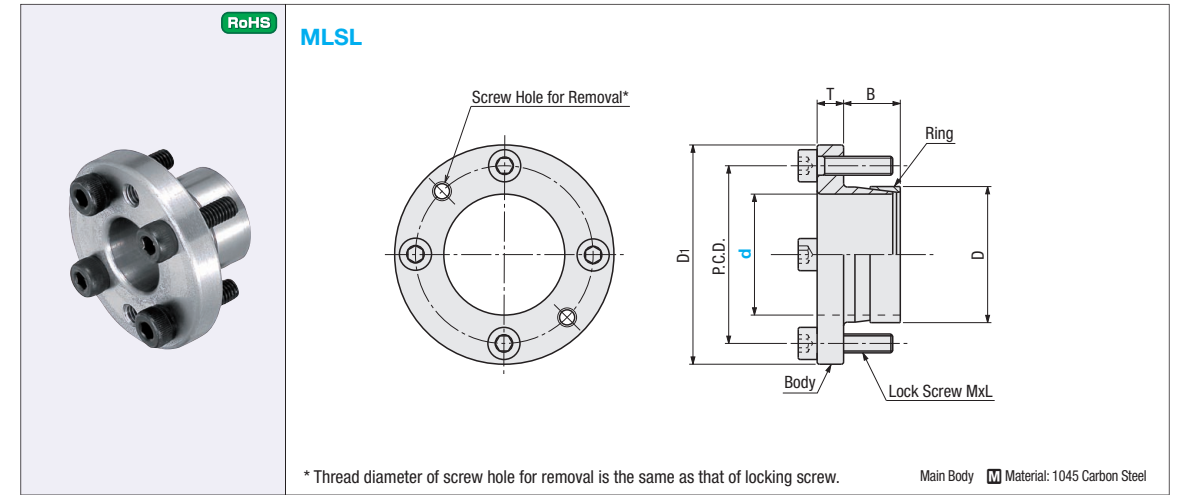

\* Thread diameter of screw hole for removal is the same as that of locking screw.

Main Body Material: 1045 Carbon Steel

Part Number	Type	d	D	D1	P.C.D.	T	B	Locking Screw		Max. Allowable Torque (N-m)	Allowable Thrust Load (kN)	Mass (g)	Unit Price
								MxL	Qty.				
MLSL	5	8	21.5	15	4	9.5	M3x10	3	1.9	4.2	1.69	13	
										5.6	1.87	15	
										8.5	2.12	17	
										18	3.59	28	
										23	3.76	31	
										37	5.21	52	
	10	13	29	21	5	11.5	M4x18	4	3.9	39	5.10	55	
										42	5.17	57	
										45	5.23	59	
										49	5.12	71	
										97	9.68	103	
										110	9.98	101	
	15	19	37	27	7	15	M5x20	4	7.8	121	10.0	106	
										124	9.90	119	
										141	10.0	118	
										149	9.89	135	
										149	9.89	135	
										149	9.89	135	

kgf/mm²=MPa x 0.101972

Ordering Example: Part Number **MLSL10**

Price [Configure Online](#)

Days to Ship [Configure Online](#)

### Hub Minimum O.D. Table

kgf/mm²=MPa x 0.101972

d	Side Surface Pressure of Hub MPa	H Hub Minimum O.D.			Hub Machining Depth L1
		Yield Point Stress of Hub Material (MPa)			
		206	294	392	
		FC350 1018 Carbon Steel 1010 Carbon Steel	65-45-12 S.G. Cast Iron 1035 Carbon Steel	FCD Cast Iron 600 1055 Carbon Steel	
5	134	21.5	21.5	21.5	8
6	132	23	22.5	22.5	
8	123	25	24.5	24.5	
10	153	38	29	29	9.5
12	139	39	31	31	
14	161	56	38	36	
15	149	52	38	37	11
16	143	52	39	38	
17	138	52	39	39	
19	118	51	42	42	12
20	198	-*	62	49	
22	196	-*	64	51	
24	184	-*	64	52	12
25	169	101	63	53	
28	160	96	64	55	
30	145	89	66	57	

\* Not available.

### How to Determine Hub O.D.

After selecting the MechaLock size, hub size and material, confirm that the selected values meet the conditions Hshub in the right-hand Hub Minimum O.D. Table.

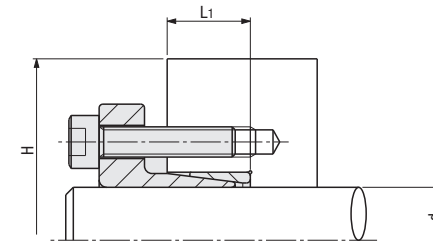

### Recommended Tolerance of Shaft and Hub / Roughness of Surface

Shaft O.D.	h7(g6)	Ra1.6 or less
Hub I.D.	H7	Ra3.2 or less